

IP BOLD - Door Phone

IP BOLD – Tx
IP BOLD – TxC
IP BOLD – TKx
IP BOLD - TKxC



Installation and operating instructions

Welcome

Congratulation to purchase modern VOIP door entry system “VoIP Door Phone **BOLD**” IP **BOLD**. This door entry widely satisfy your needs for communication to visitors of your company, homes, schools etc...

Simply VoIP means “**Voice over Internet Protocol**” – this door entry is connectable to IP network and allows 2 ways of calling. Either P2P (peer to peer) – it means call directly to IP adress of other VOIP device or registrates to SIP server (as SIP client) and then call phone number.

To each button you can assign 5 phone numbers with possibility of progressive or simultaneous dial.

The door entry IP BOLD is offered with 1, 2 or 4 button with or without full colour camera as same as with or without keypad.

The door entry IP BOLD is powered from 12V power supply which supply also electrical lock at door. It might be powered also by PoE (Power over Ethernet). By features remind hands free phone. To basic features belongs possibility open up 2 doors via connected electrical locks as same as user friendly configuration by WEB interface.



Producer progressively improves features of the unit (firmware). The door entry IP BOLD allows whenever upgrade the firmware by newest version via PC. Latest firmware version you can download from www.alphatech.cz . Necessary guides you find at page 79. We recommend always use latest firmware version which brings new features as same as eventual correction of errors of previous versions. At www.alphatech.cz you can also find latest versions of user documentation.

ALPHATECH
Tech

Manual version V1.7 17-10-2018

Valid for firmware – V3.4.5x

Alphatech spol. s r.o.

Jeremenkova 88

140 00 Praha 4

Tel/fax: 272103334

www.alphatech.cz

info@alphatech.cz

Contents

1	BASIC DESCRIPTION.....	6
1.1	FEATURES	6
1.2	USED TERMINOLOGY.....	7
1.3	MODULES COMPOSITION	9
1.4	IP BOLD CONNECTION	12
1.4.1	<i>IP BOLD basic board</i>	12
1.4.2	<i>Relays connection</i>	15
1.4.3	<i>PoE</i>	19
1.4.4	<i>Usage of door contacts</i>	19
1.5	INSTALLATION OF IP BOLD	21
1.5.1	<i>Wall mounting installation</i>	21
1.5.2	<i>Montage dimension (model without keyboard)</i>	22
1.5.3	<i>Montage dimension (model with keyboard)</i>	23
1.5.1	<i>Montage dimension with Roof (model without keyboard)</i>	24
1.5.2	<i>Montage dimension with Roof (model with keyboard)</i>	25
1.5.3	<i>Open and close of cover</i>	26
1.5.4	<i>Name cards changing</i>	27
1.5.5	<i>Micro SD card</i>	28
1.5.6	<i>Button numbering</i>	28
2	SERVICE OF IP BOLD.....	29
2.1	SIGNALLING OVERVIEW	29
2.2	VISITOR AT DOOR.....	29
2.2.1	<i>Button press – outgoing call</i>	29
2.2.2	<i>Button press – code lock</i>	30
2.2.3	<i>Keypad usage</i>	30
2.2.4	<i>Call</i>	31
2.3	VISITOR INSIDE BUILDING	31
2.3.1	<i>Outgoing call</i>	31
2.3.2	<i>Incoming call</i>	31
2.4	VIDEO	32
3	PARAMETRES PROGRAMMING	33
3.1	WEB INTERFACE ACCESS.....	33
3.1.1	<i>What you should know</i>	33
3.1.2	<i>Login</i>	34
3.2	CURRENT STATUS	35
3.2.1	<i>Language settings</i>	36
3.3	IP NETWORK SETTING	37
3.3.1	<i>IP Network setting</i>	37
3.3.2	<i>SIP setting</i>	40
3.3.3	<i>WEB server</i>	44
4	IP BOLD - installation and operating instructions	

3.4	BASIC SETTING.....	46
3.4.1	<i>Phone book</i>	46
3.4.2	<i>Relays</i>	49
3.4.3	<i>Door sensors</i>	56
3.4.4	<i>Setting SNMP</i>	58
3.4.5	<i>Time profiles</i>	59
3.4.6	<i>Date and time setting</i>	61
3.4.7	<i>E-mail</i>	62
3.5	EXTENDED SETTING.....	64
3.5.1	<i>DoorPhone</i>	64
3.5.2	<i>Audio setting</i>	67
3.5.3	<i>Audio codecs</i>	68
3.5.4	<i>Video setting</i>	69
3.5.5	<i>Video watching (PopUp programm)</i>	70
3.5.6	<i>Video codecs</i>	71
3.5.7	<i>Streaming</i>	72
3.6	SERVICE.....	74
3.6.1	<i>Restart</i>	74
3.6.2	<i>Configuration</i>	75
3.6.3	<i>Language and style</i>	76
3.6.4	<i>Style and language preparation</i>	77
3.6.5	<i>Firmware upgrade</i>	79
3.6.6	<i>Logfile</i>	80
3.6.7	<i>License</i>	82
3.6.8	<i>Sound files</i>	83
4	TECHNICAL PARAMETRES.....	84
4.1	ELECTRICAL PARAMETRES.....	84
4.2	MECHANICAL DIMENSIONS.....	84
4.3	VIDEO PARAMETRES.....	85
4.3.1	<i>Requests</i>	86
5	GENERAL INSTRUCTIONS AND CAUTIONS.....	87
1.1	GENERAL INSTRUCTIONS.....	87
1.2	HANDLING OF ELECTRICAL WASTE AND SPENT BATTERIES.....	87
1.3	NOTES ON USING OPEN SOURCE SOFTWARE (GPL).....	88

1 Basic description

1.1 Features

- audio is full duplex with ECHO cancellation
- phone book for 999 subscribers (when keypad is used)
- every subscriber has more phone numbers with progressive or simultaneous calling
- Email sending when is unreachable including attachment with pictures
- 10 time plans with week programm
- 4 relays. 2 included on board with possibility connect 2 independent locks for door opening and 2 virtual (webrelays) (for remote control of IP relay or relays synchronization)
- Relays system via synchronization allows combination of any mode (progressive opening, 2 pulses etc..)
- 10 shared adjustable codes for every relay + every subscriber has own code for every relay
- 1 and 2 button versions can use door sensors
- SNMP usage possibility
- Real time clocks from NTP or SIP server
- Extendable possibilities of buttons functionality, light intensity settings, call duration restriction, keypad mode etc...
- Audio signalling settings, saving own tones or messages
- Multilanguage support
- Multilevel loading and configuration refresh
- Reliable firmware upgrade
- *Logging system with possibility of data saving to MicroSD card (we prepare)*
- *Pictures as same as video saving possibility to MicroSD card (we prepare)*
- WEB interface management
- Power supply 12V or PoE (Class 0 - 12,95W)
- Ethernet – 10/100Mb with standard 10BaseT and 100BaseTx
- Unit start within 10 seconds
- Linux operating system
- USB connection of integrated webcam. Video transmission to webbrowser - JPEG, video transmission to VoIP phones - stream H.263, H.264
- SIP connection P2P or PBX (SIP server) system, switchable in web interface
- SIP 2.0 protocol , define RFC3261

1.2 Used terminology

- **Incoming call** - Connection between a Brave and a phone made by selecting an option on the phone. The Brave connects the call after set number of rings. The Brave can be programmed from the phone following a connection by inputting a password.
- **Outgoing call** - Connection between the Brave and a phone made by choosing an option on the Brave (i.e. Pressing a button).
- **External code** - Combination of 1-4 buttons or keyboard keys (after pressing the key symbol) for a relay activation. [External = enter code outside the building]
- **Internal code** - Combination of keys on phone keyboard for a relay activation (by DTMF). [Internal = enter code inside the building].
- **Code lock** - Function for relay connections by inputting a combination of up to 1-4 buttons or keyboard keys (after pressing the symbol )
- **Ethernet** is technology which is used to build up local networks (LAN)
- **LAN** - Local Area Network (local network) mark PC network which cover small geographical area (for example homes, office, etc...).
- **10Base-T** As transmission medium use twisted twoline cable with rate 10 Mbit/s. It used 2pairs of structured cabling from four.
- **100Base-TX** Version with transmission rate 100 Mbit/s, which is named **Fast Ethernet**. It used 2 pairs UTP or STP cable category 5.
- **Twisted 2line** or also **twisted pair** is cable type which is used in PC networks. Twisted 2line is created by cables pair which are regularly twisted in the length and after pairs are twisted together.
- **UTP**, Unshielded Twisted Pair
- **STP**, Shielded Twisted Pair
- **WEB** - World Wide Web (WWW, shortly **web**), is mark for application of http internet protocol
- **HTTP** (Hypertext Transfer Protocol) is internet protocol design for exchange of hypertext documents in format HTML
- **USB** (Universal Serial Bus) . Modern way of accessories connection to PC
- **Video codec** (compound of word begins „**coder** and **decoder**“) . Compression **H.263** is derived from MPEG-4, **H.264** is coder for format MPEG-4 AVC. **MPEG-4** is kind of video compression – decrease of pictures sequence data flow
- **JPEG** is standard method of loss making compression used for savings PC pictures
- **Voice over Internet Protocol** (shortly **VoIP**) is technology allows transmission of digitized voice in body of family protocols **UDP/TCP/IP** packets via PC network . It is used for calling via internet, intranet or any other data connection.
- **TCP/IP** contents set of protocols for communication in PC network and it is main protocol of worldwide network Internet.
- **IP adresa** is number which definitely identify network interface in PC network which used IP protocol.

- **DHCP** (Dynamic Host Configuration Protocol) is application protocol from family TCP/IP. It is used for automatic assign of IP addresses to individual computers in PC network. Due this simplify its management
- **Internet** is worldwide system of mutually connected PC networks
- **Intranet** is PC network similiar to internet but it is „private“. It is designed jsut for small group of subscribers (for example workers in some company)
- **PoE** (Power over Ethernet) is powering via data network cable.
- **NTP** (*Network Time Protocol*) is protocol for synchronization of internal PC clocks
- **NAT** (*Network address translation*) is a method of remapping one IP address space into another by modifying network address information in Internet Protocol (IP) datagram packet headers while they are in transit across a traffic routing device
- **STUN** (*Session Traversal Utilities for NAT*) is a standardized set of methods and a network protocol to allow an end host to discover its public IP address if it is located behind a NAT.
- **SIP User Agent** - every SIP user agent (phone, software, device) identifies itself with a string. The syntax of this string is not defined, but a common practise is „device name + version“

1.3 Modules composition

Door entry IP BOLD includes modern technology, timeless design and user friendly installation and service.

Door entry IP BOLD is equipped by 2 relays and PoE feeding.

Basic models are different by using of keypad or full colour wideangle camera.

Version with camera has integrated fully colour wideangle camera on basic board. Version without camera used different plexi cover shield on top of the unit.

IP BOLD-T1	1 button audio
IP BOLD-T2	2 button audio
IP BOLD-T4	4 button audio
IP BOLD-T1C	1 button audio , colour camera
IP BOLD-T2C	2 button audio , colour camera
IP BOLD-T4C	4 button audio , colour camera
IP BOLD-TK1	1 button audio and keypad
IP BOLD-TK4	4 button audio and keypad
IP BOLD-TK1C	1 button audio and keypad, colour camera
IP BOLD-TK4C	4 button audio and keypad, colour camera



IP BOLD-T1C



IP BOLD-T2C



IP BOLD-T4C



IP BOLD-TK1C



IP BOLD-TK4C

Next is possible IP BOLD eqipt by roof
For short model without keyboard



Roof small (BOLD Shield S)



Roof big B - Tx (BOLD Shield B)

For long model with keyboard



Roof small (BOLD Shield S)



Roof big K - TKx (BOLD Shield K)

1.4 IP BOLD connection

The IP BOLD includes basic board differently equipped. To the basic board is possible connect 1 or 2 button boards. Further is possible connect keypad in version TK.

1.4.1 IP BOLD basic board

The basic board is the same for all models of IP BOLD door entry. The difference is just camera module (with or without). The PoE modul is in standard (according directive IEEE802.3af) as same as connectors for button and keypad connection , MicroSD card reader and 2 relays (first relay has switching contact [NO COM NC] and second relay has closing contact only [NO COM]).

The basic board schematics at picture bellow and all important parts are marked in circle with description.

1. Mounting holes
2. Cabling holes (UTP, electrical locks connection, power supply)
3. Switching contact screw terminal of **first relay** (NC= closed in stand by, NO=open in stand by and COM= common output)
4. Switching contact screw terminal of **second relay** (NC= closed in stand by, NO=open in stand by and COM= common output)
5. MicroSD card slot – Insert SD card before switch ON of door entry and do not také out during all operation time!
6. **Input** for powering IP BOLD 12V AC / DC (consumption cca 300mA max.)
We reccomend use DC power supply
7. Output 12V DC, max. 300mA, for example to power low consumption electrical lock via PoE powering of IP BOLD
8. UTP cable connection (Ethernet, LAN,net)

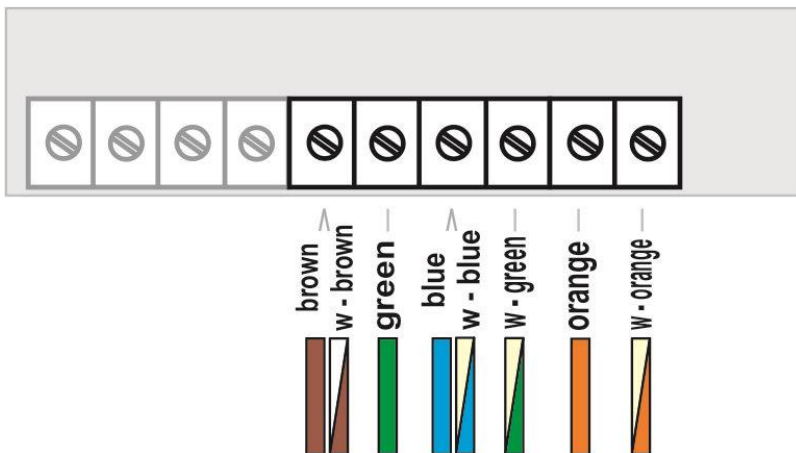

9. The LED to control network activity, green = connection 100M LAN, yellow = data transmission on the LAN
10. Connector to Connect keypad module
11. DIP switch
 - 1 – always ON (servis purpose only)
 - 2 – OFF, when is ON during start then default IP adress 192.168.1.250 is setup and use default style. Name is *admin* and password is *1234*. To see the video is the name *video* and password *1234* (if required). After, do **not forget** move back **DIP switch 2 to position OFF !**
12. IP module
13. Connector to connect 2 buttons or 1 button and 2 door sensors (Info about door closing)
14. Camera lens (At camera models only). The lens angle is 80° (or 110° - newest model), max. resolution 640x480.
15. Signalling 2 colours LED
 - red – call picked up
 - green – call in progress
 - red+green – relay closed
16. Extra camera light at night – white LED with intensity setting
17. Sensor of surrounding lighting – according setup control name cards lighting as same as camera lighting
18. Connector to connect up 2 buttons
19. Connector to connect speaker
20. Connector to connect microphone (polarity attention)

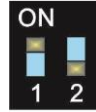

During installation and normal operation as well as during cable connections, handling SD card **is not necessary to move the grid with a speaker and microphone**. Under this part are the connectors, which are connected by the factory and the DIP switch, which is to be used only in a crash FW upgrade.

It is **recommended** to cover **not manipulate** with this because careless movement can wires from the microphone and speaker damage components on the motherboard.

Never not overcome greater resistance when shunting the speaker grid and prefer to carefully look under the cover, where it holds!

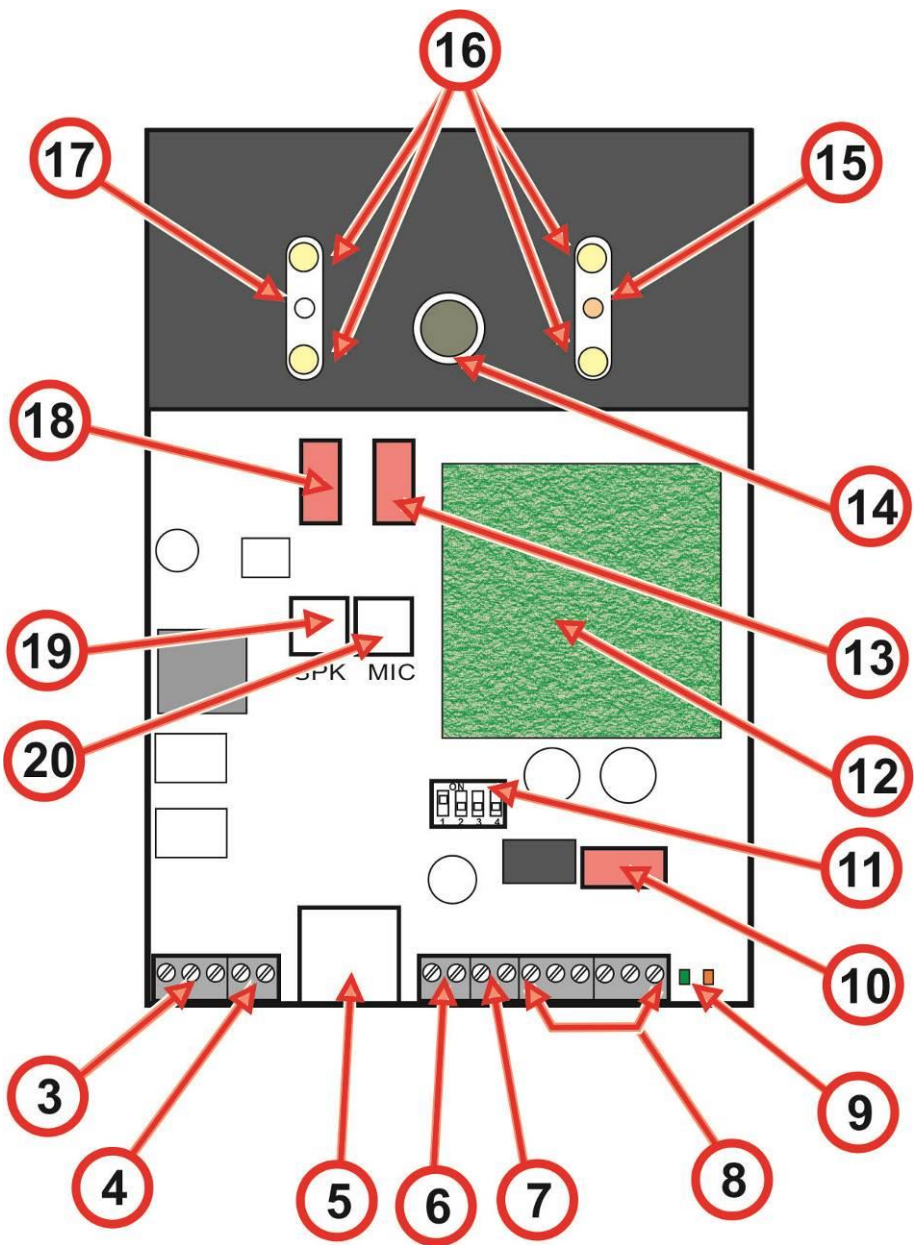

1.4.2 Relays connection

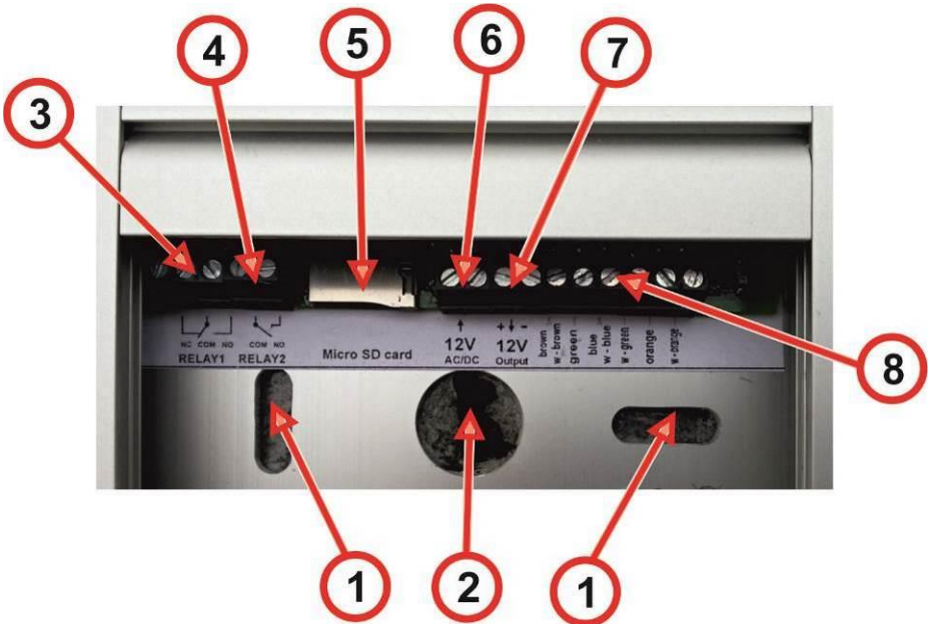

Relay contacts connection (3) and (4) is on the picture. Marking **"NO"** means in stand by open contact, **"COM"** means shared output (middle) and **"NC"** means in stand by closed contact. Contacts of both relays are mutually galvanically isolated as same as isolated from othe IP BOLD components.

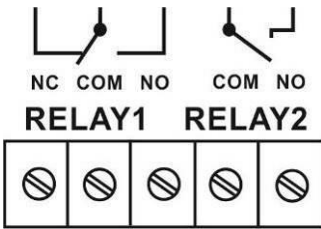

It is recommended use for IP BOLD PoE powering (according directive IEEE802.3af) or AC voltage min.11V - max.15V or DC voltage min.12Vss - max.18Vss. which is connected to screw **"12V"**. The IP BOLD consumption is max.300mA. This powering is possible simultaneously use for electrical lock(s) feeding. Then you have to consider el.lock consumption. In practise mostly used is AC / DC power supply 12V/1A÷2A.

Possibilities of relays connection are at following pictures:

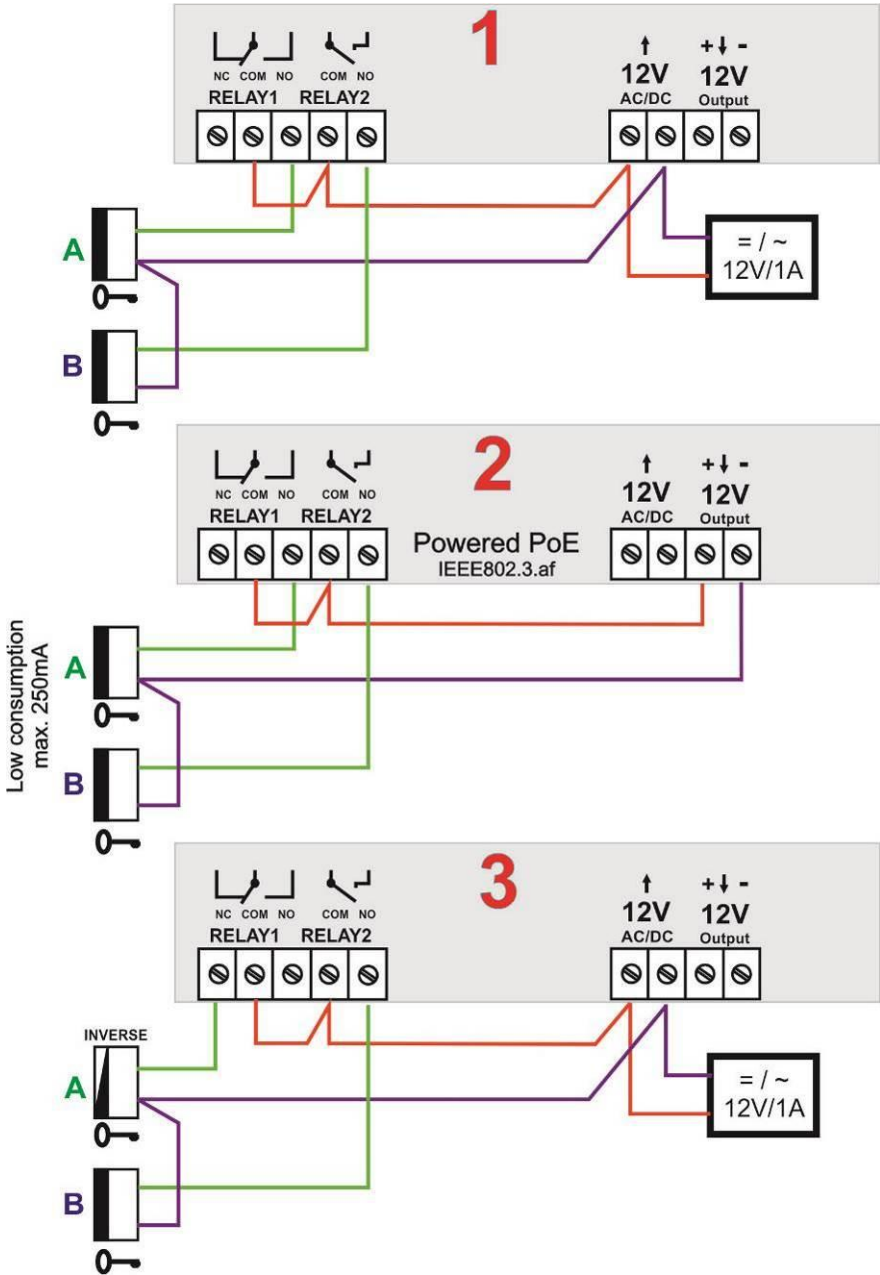

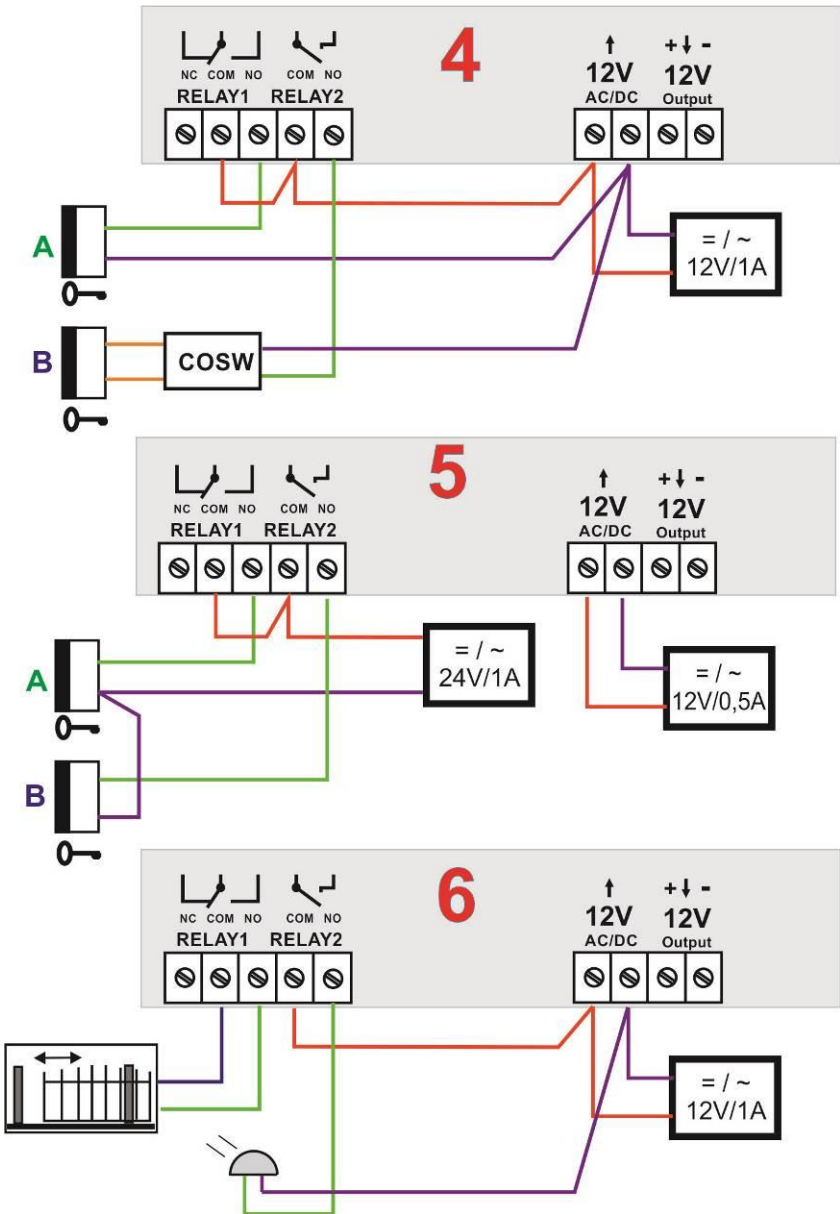

1. Standard electrical lock connection. This connection is used most often. One shared power supply feeding door entry IP BOLD and both electrical lock. Current loading of PSU depends mainly on used el. Locks. Standard el. Lock has current consumption 0,6A – 1,0A. As next you have to consider possibility of both relays activation simultaneously. When not then 1A PSU is fine. When yes then use 2A PSU. When you use low consumption electrical lock then PSU 1A is fully acceptable.
2. The second most often used connection is by powering from PoE. There is advantage of no extra PSU necessity. However 2 conditions must be followed: Electrical locks must be low consumption as same as relays must not be activated simultaneously (via follow).
3. This connection is version for reversal lock (magnetic lock). Therefore switchable contact is lead out from first relay only the second (B) electrical lock is standard. When you need connect inversal lock to second relay as well then you have to use extra relay – picture 3a:

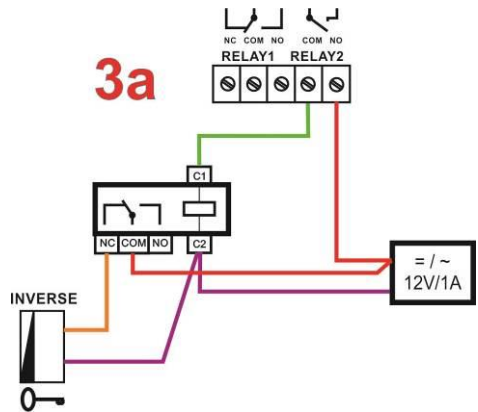

4. Connection with security transmission - “security” activation of B electrical lock . Security transmission is between door entry IP BOLD and module COSW (code switch). Therefore we recommend place COSW module close to electrical lock. For correct operation is necessary setup in IP BOLD door entry and COSW module the same code (via follow). The A electrical lock is in standard connection.
5. Connection with 2x PSU. When you need different feeding for electrical lock or you want separate powering of lock from door entry you can use 2 individual powering circles.
6. Examples of other devices (beside el.locks) connection. To the first relay is connected sliding door controller and to second relay is connected extra bell (siren).

1.4.3 PoE

The IP BOLD is equipped by circuit for powering via UTP cable – PoE. When you have IP switch with PoE, or you have PoE PSU (box of adapter size inserted into UTP cable input – according directive IEEE802.3af) then you dont need extra 12V PSU for door entry powering.

When you use electrical lock for door opening then you have to use PSU for powering of door electrical lock (in relays contacts circuit only), or use low consumption electrical lock and for electrical lock powering use output screw „12V output” (7). When is used PoE then 12V/300mA is available.

CAUTION: There must not be activated both electrical locks simultaneously.

It might be reached for example by relays synchronization and setup progressive door opening (setting is described in follow capture relays setting)

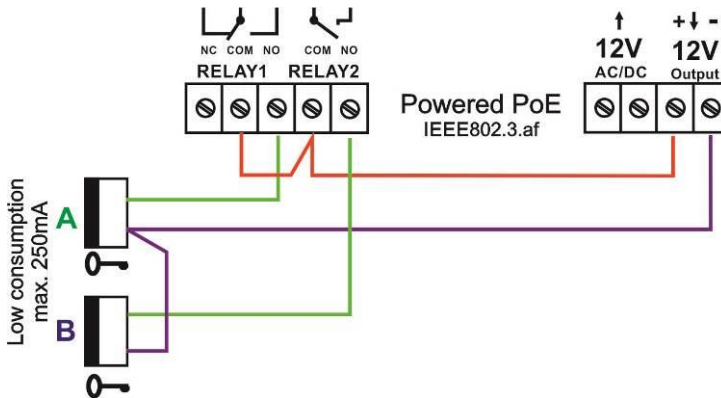

1.4.4 Usage of door contacts

The door sensors might be connected max. 2 to door entry IP BOLD. There are designed for transmission of door close informatik. This information is display on initial screen (under picture from camera). It is also transmit to UDVguard applications. Further possibility is use SNMP.

The door sensor is ether part of electrical lock or it is ordinary magnetic contact used in security. It is connect as button to screw terminal (13), eventually to screw terminal (18). Those screw terminals are designed for buttons connection. Door sensors connection allways require special button module with cable for door sensors connection. This feature is optional. Therefore **you have to order in advance.**

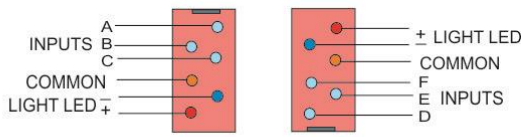
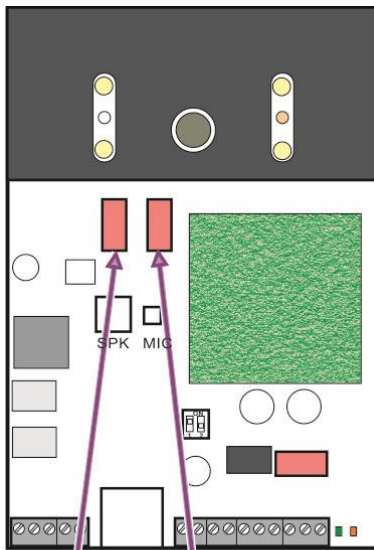

Connection one button with door sensors:

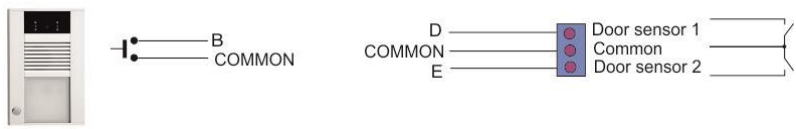

Connection two buttons with door sensors:

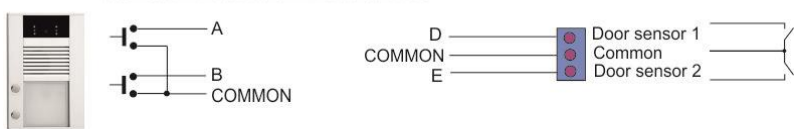

Connection four buttons with door sensors:

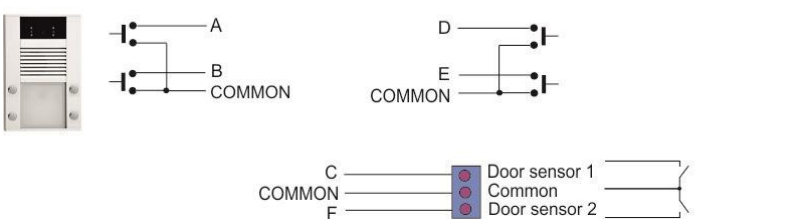

1.5 Installation of IP BOLD

1.5.1 Wall mounting installation

Installation place

To reach good video quality the camera must not point directly to

- sun lighting
- strong light sources
- light or strongly reflective walls

Installation height

Installation height of outdoor video station should be selected according camera scan range (via picture). People with average height will be at installation 160 cm from ground optimally scanned.

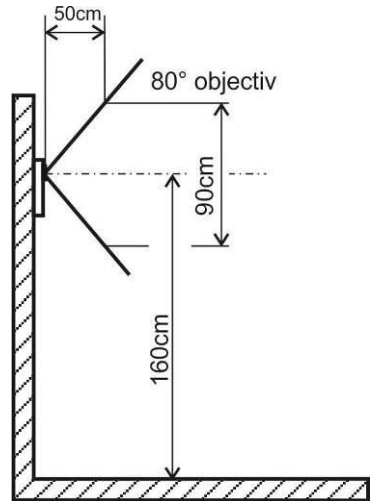

Installation is done by screws and wall plug.

Recommended:

- Wall plug diameter **8mm**
- Screw is twist with halfround head . Diameter **5mm** lenght **35mm**

We recommend following wall mounting procedure:

- Open the unit cover (via follow capture)
- Lead in cable (wires) via cable hole (2)
- Fix the unit safely to wall (screws + wall plugs) by fixing holes (1).
- Be carefull to dont squeeze setting block on back side.
- Connect the wires (follow instructions in next capture)
- Replace the unit cover (via following capture)

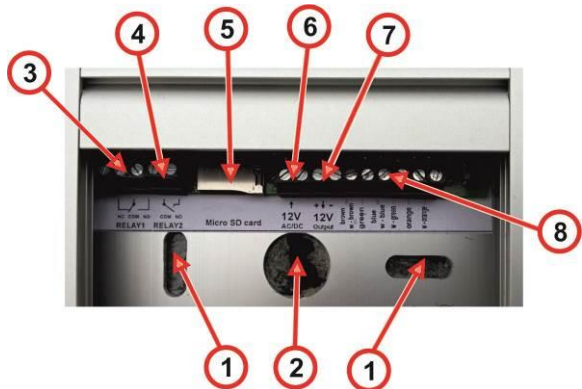

1.5.2 Montage dimension (model without keyboard)

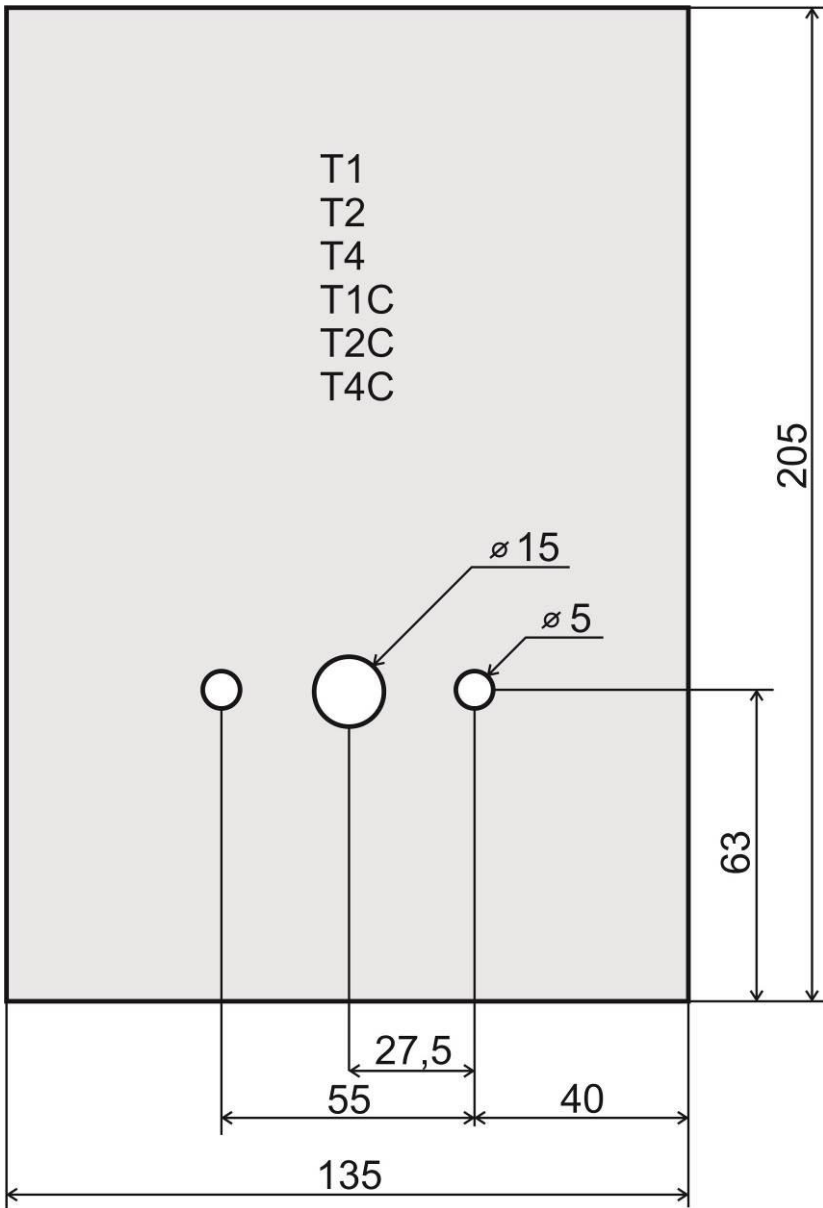

1.5.3 Montage dimension (model with keyboard)

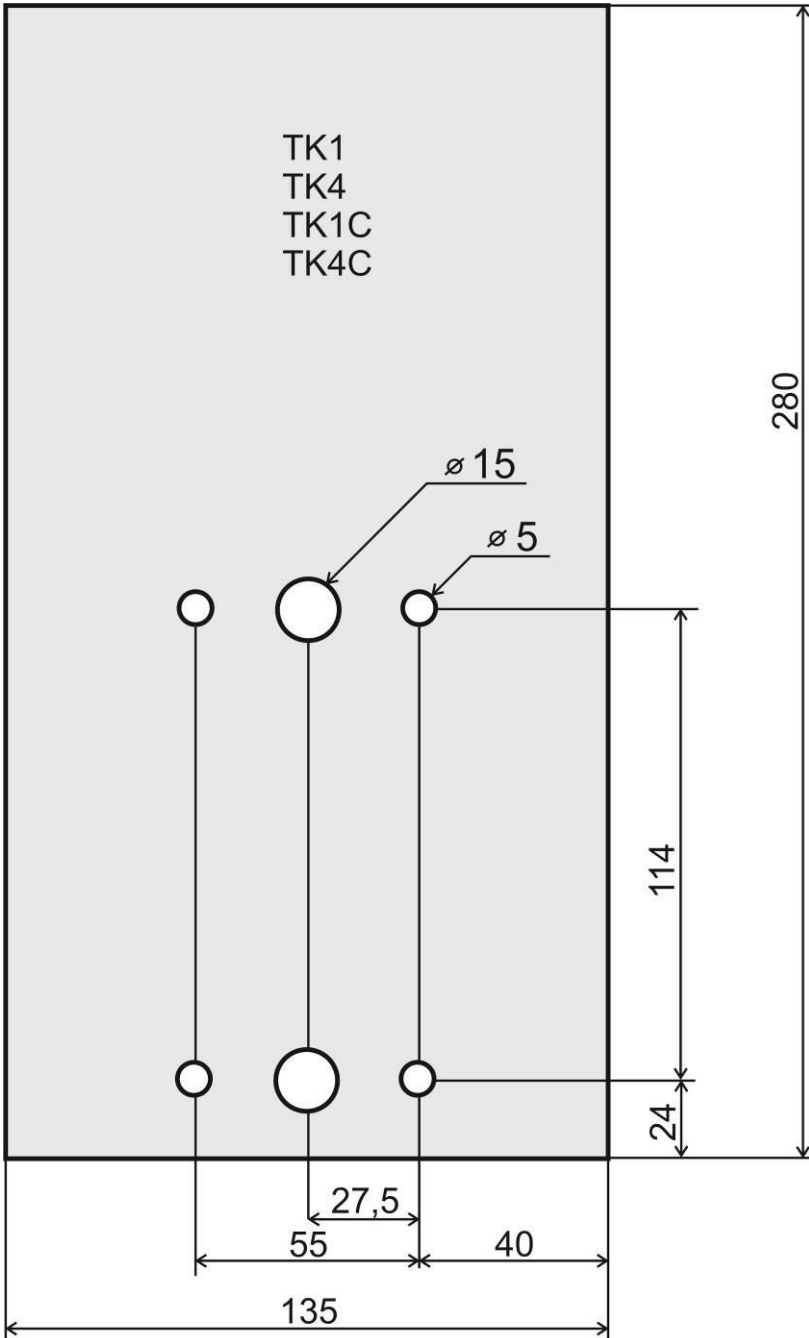

1.5.1 Montage dimension with Roof (model without keyboard)

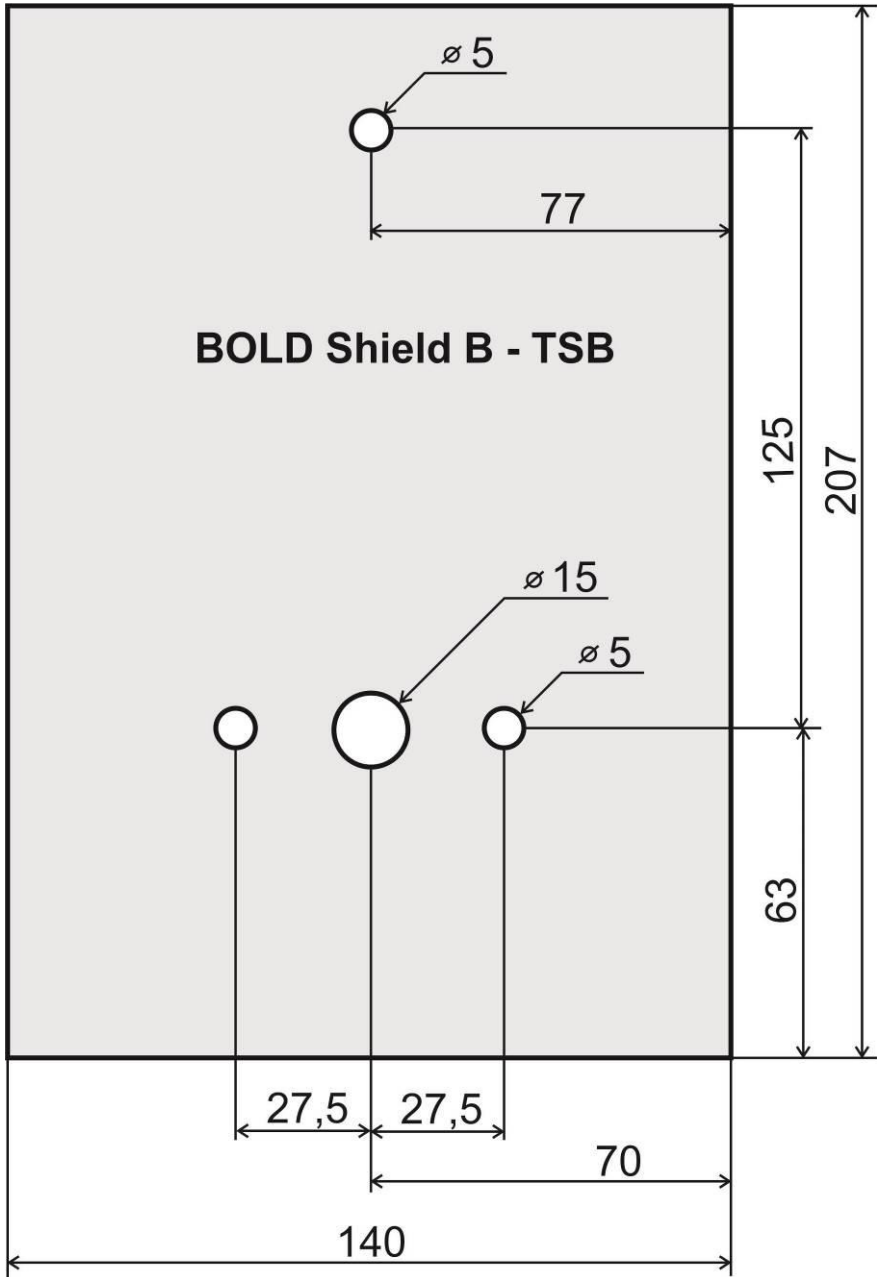

1.5.2 Montage dimension with Roof (model with keyboard)

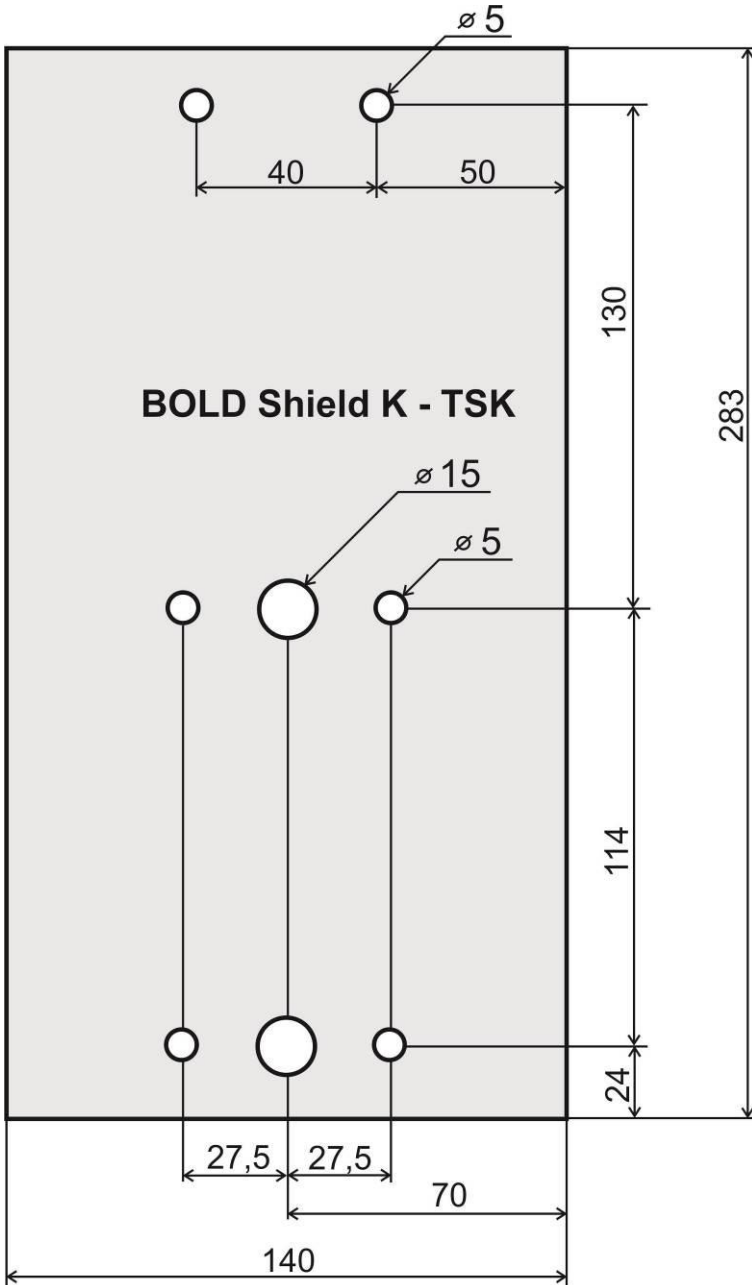

1.5.3 Open and close of cover

Cover opening

Bottom lath is connected to alu profile by 2 internal sixedge screws

- (1) Screw up to middle way by enclosed key those screws
- (2) turn bottom lath to left without its complete taking
- (3) slide out name card plexi

Cover closing

Slide name plexi under lath
Turn bottom lath to right to groove reach screw. Screw down the screw.

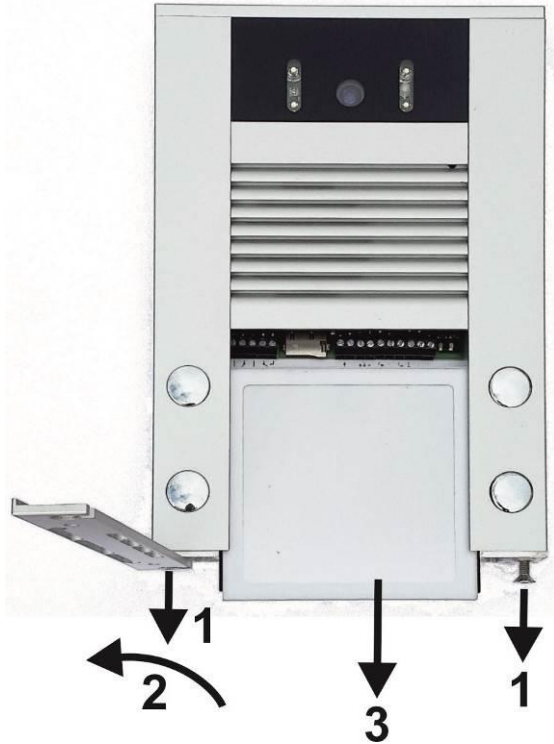

- When you slide name plexi be aware to dont damage seal ruber in grooves
- When you install next device please dont forget that name plexi is slide out in down direction. Dont install any other device closely under the unit
- Do not seal up the unit in any case! Condenseth water must flow away.

General recomendation for connection

To dont damage the unit please use enclosed screw driver.

Pay attention:

- dont put cable under lighting diod to disturb name cards lifting
- dont squeeze cable under setting block on back side of unit

1.5.4 Name cards changing

Name cards writing

Templates you will find on our website www.alphatech.cz

1. Write desired names into template.
2. Print out name cards to special foil* and cut them of.
3. Release pockets on external edge of name plexi by delivered plastic board.
4. Slide name cards from side to spaces in name plexi

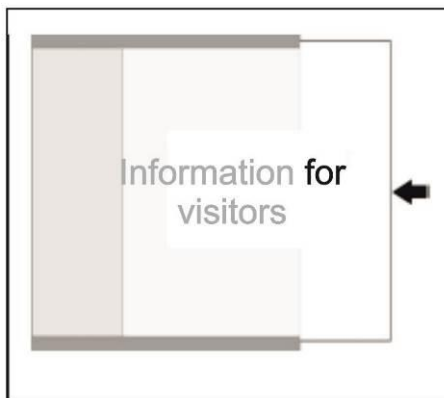

** We recommend print out the name cards to special resistant foil. This foil you can directly order from us: Polyester foil for name cards DIN A4*

1.5.5 *Micro SD card*

Micro SD card is used to save users sound files and in near future also to save pictures, video, as record machine.

When you select users tone and microSD will not be inserted then tones of basic signalling will be used.



Never take out SD card during door entry operation!

1.5.6 *Button numbering*

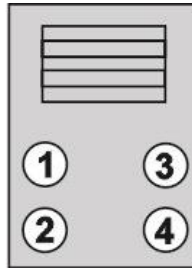
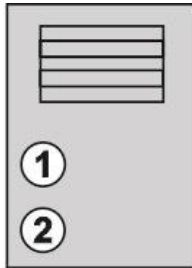
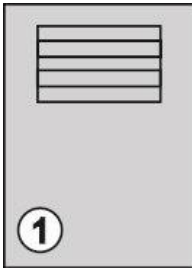

2 Service of IP BOLD

2.1 Signalling overview

The door entry IP BOLD signalling acoustically stages which occurs during operation. Further signalling is by 2 colour LED (placed right under black plexi). Acoustical signalling for each status mentioned in bellow table might be switched off or might be used default tones “beeping” or recorded user sound.

Status	Tone	LED
Call start	Adjustable / user programmable	RED
Call end	Adjustable / user programmable	OFF
Call not possible (busy)	Adjustable / user programmable	RED
Confirmation of code insert	Adjustable / user programmable	GREEN
End of call notification	Adjustable / user programmable	GREEN
Rlay closing	Adjustable / user programmable	RED+ GREEN
Error	Adjustable / user programmable	
Button press	Adjustable / user programmable	
Call establishing	-	RED
Call in progress - talk	-	GREEN
Service mode (start boot)		GREEN
Linux start		RED
Rescue WEB start		RED blinking

* - indication needs active acoustic signalling of appropriate relay

2.2 Visitor at door

Visitor at door is person who wants enter inside the building.

2.2.1 Button press – outgoing call

Outgoing call is call from door entry (start by visitor). After door entry dial is ringit phone inside the building.

Door entry buttons have name cards with names and functions of people inside the building. The visitor press appropriate button and door entry start calling imediately (button is not first digit of code keylock) or delayed (time between button press) .The door entry dial preprogrammed number . Dialling number is different according setting in phone book:

1. Phone book position for selected button must be permitted
2. Must be fill min. 1 from 5 phone numbers (or IP addresses in P2P mode)
3. At filled phone number is active time plan in appropriate time or no plan is selected.

When is filled up more numbers then selection of phone number is up time plan and next are numbers dial in order (1 – 2 ... 5) or numbers might be dial simultaneously and which is picked up first it has the talk.

Both versions of dialling might be combinated. For example is possible call to 1. and 2. Phone number simultaneously. When call is not picked up until certain time then number 3 is dialled.

Repeated button press might have following functions:

- Nothing happen
- Dial again
- Call is ended

Since version 3.0.38 is in guard IP BOLD new property that upon arrival "SIP Ringing" or the "Session progress" will not pass audio, but lets local bell ringing. But the video link (if offered by the counterparty in the SDP). Thus, it is possible with a suitable videophone (eg. Grandstream GXV3275 - "Preview" button) to see who is standing at the door, and accordingly it let in the building or not, without having heard anything from IP BOLD.

2.2.2 Button press – code lock

Door entry IP BOLD buttons have feature of code lock. By progressive buttons press you can activate appropriate relay. The codes for this feature are either shared by all subscribers (relays setting) as same as individual (each subscriber has in phone book own private access code).

Caution: code might be done from available buttons only (for example model IP IP BOLD-T4 has available 1,2,3,4). At models TKx is code for lock available on keyboard.

When button number is first digit o any code then dialling from this button is delayed about “time between button press” for code evaluation.

It is also necessary mention feature relay closing by press of selected button (for example for function bell activation). This feature programmable in relays petting.

2.2.3 Keypad usage

At models with keypad are 3 ways of dialling:

- By button press as models without keyboard
- Direct phone number dial from keypad (When you insert IP address in mode P2P then dot between numbers group is inserted by  as is usual on IP phones)
- By dial of memory number (phone book have 999 subscribers. So by dial of numeral 1-999 is possible make same

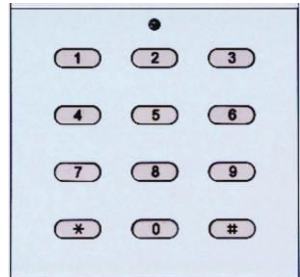

fiction as button press).

End of call you can make allways by button press 

When keypad is connected the fiction of code lock is extended

It is possible use whole range of codes (numerals 0-9). The code for relay activation is differentiate from phone number dial by pressing  in the beginning. Then is code for relay activation.

2.2.4 Call

Door entry IP BOLD has adaptive ECHO canceller. The Echo disappear usually within first 5 seconds of call. The call is then full duplex. The end of call happen:

- Called party hang up
- Call duration time is over (when is setup)
- By button press(when is setup)

2.3 Visitor inside building

By person inside building is person who is in communication with door entry IP BOLD.

2.3.1 Outgoing call

Outgoing call is call from door entry (start by visitor). After door entry dial is ringit phone inside the building. When call is picked up you can talk to visitor at door and by code dialling you can activate relay. Door entry sends 10sec before call end notification about time limit of call and by dial character (* / #) you can prolong the call. By phone hang up the call is ended.



All transmission ways of info about button press are available (for example code to activate relay) – either in “RTP channel – RFC2833” or in “SIP info” and “inband DTMF”.

2.3.2 Incoming call

Incoming call is call to door entry (start by person inside building). After dial of extension number or IP adress where is connected door entry IP BOLD the door entry is ringing and after preprogrammed number of rings picks up the call. You can talk. Possibilities are the same as outgoing call (activate relay, prolong the call etc.).

2.4 Video

At models with camera is possible received video as follow:

- IP phone with LCD display
- PC – WEB browser
- PC with programm UDVguard (www.alphatech.cz)
- PC with general programm for video watching (for example VLC)
- Android device (smart phone, tablet) UDVguard (Google Play)
- Apple device (smart phone, tablet) UDVguard (iTunes)

Video formats: JPG, MJPG, H.263, H.264

Video for WEB:

Internet Explorer, Mozilla, Opera, Firefox... - (set of JPG pictures - Port 80) it is used repeated http request „IPaddress/video.jpg“

programm PopUp (UDVguard) - (MJPEG stream - Port 80) is used http request „IPaddress/video.mjpg“ (sometimes is reload necessary to run). This video is more fluent and has less network strain.

Stream video for IP phones:

H.263 and H264 is established by IP BOLD door entry and IPvideo phone over SIP/SDP protocol on standard SIP port. The video (as same as sound) then runs by RTP protokol on ports agreed over SIP (usually 9078).

rtsp request „rtsp://IPaddress/video.264“

or rtsp request „rtsp://IPaddress/video.263

Video parametres:

JPG Pictures are created in IP modul and for all transmit protocols are the same .The Size (resolution) of video is selected in "Video setting" on WEB. Maximal resolution is defined by USB camera type and mostly is 640x480 Stream H.263 knows CIF resolution (352x288). It means bigger JPEG is cut and smaller framed.

Frequency (1-15 picture./sec) JPG Picture is selected in "Video setting" on WEB.

Frequency MJPG and Stream H.263 coming from camera. It is used every second and reset is between 7-15 pictures/sec. Higher resolution brings decrease of Pictures/ sec. (limited by processor efficiency)

Ports:

Port **80** for http (WEB pages even JPG / MJPG video on them)

Port **5060** for SIP

Ports RTP with oposite party communicates over SIP. Usually Port **7078** suggested for audio and Port **9078** for video

Port **554** video(H264 and H263) provided by door entry (server) protocol RTSP

3 Parametres programming

Parametres programming is performed by ordinary WEB browser.
(Caution! version of IE V7 and lower are not supported).

3.1 WEB interface access

For successful display of WEB interface of IP BOLD door entry we go through some details.

Field length - names, titles, codes, passwords have fix length **40 characters**.
- URL and etc. have max length **255 characters**

3.1.1 What you should know

In doorphone IP BOLD is a double DIP switch. Individual switches should be in the positions shown.

- 1 – on
- 2 – off

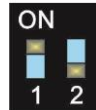

Meaning of each switches:

1. Always position **on**, this switch is only used in the manufacture or repair service.
2. If the position **on** at power (or reset) so in doorphone is set the default IP address 192.168.1.250 and uses the default style. The name is *admin* and the password is *1234*. To see the video is the name *video* and password *1234* (if required). **The operating position is off.**

Warning: If you get into a situation that you do not know the IP address set in IP BOLD or have forgotten your password, so there is reason to use the **DIP2** switch, switch it to the **ON** position and restart IP BOLD. Then you change the settings eg. Passwords or network settings. Remember to switch DIP2 into operating position **DIP2 = off** and click save and restart. After rebooting, IP BOLD is now all set according to the changes.

You should also dedicate attention into which PC network you are connected. Default door entry IP address is 192.168.1.250.

When is your PC in network setup also on segment 192.168.1.xxx then might caused a problem in network just by same IP address etc. 192.168.1.250.

In this case we recommend temporarily disconnect device from network.

When your PC is setup to different network segment than 192.168.1.xxx two possibilities are available:

1. In PC you have system Windows 7 or 8, then you can setup „network setting“ – „Protocol IP version 4“ – „Property“ – specify“ and here add IP address in PC segment of door entry for example. 192.168.1.10

2. Generally in PC setup you program temporarily own IP address. In PC door entry segment for example 192.168.1.10. After change of door entry IP address you have return setting in PC back.

Then you can setup parameters of door entry including IP address and after restart of IP BOLD door entry you can login to door entry WEB page on new IP address.

3.1.2 Login

In your WEB browser write IP address of IP BOLD door entry in default it is **192.168.1.250**. you can see picture from camera as bellow – „home screen with video“



Under picture from camera (at models without camera is empty frame only) are on the left buttons **Stop** – to stop video and **Start** for run video again. On the right is description **Setup** – after click on it will be display request for login data.

Write username and password. Username is always „**admin**“ and password is „**1234**“ (adjustable in settings). (To see the video is the name „**video**“ and password „**1234**“ - if required).

You enter now to first setting page of door entry IP BOLD. On this page is display „Current status“. All necessary data about door entry status are here.

3.2 Current status

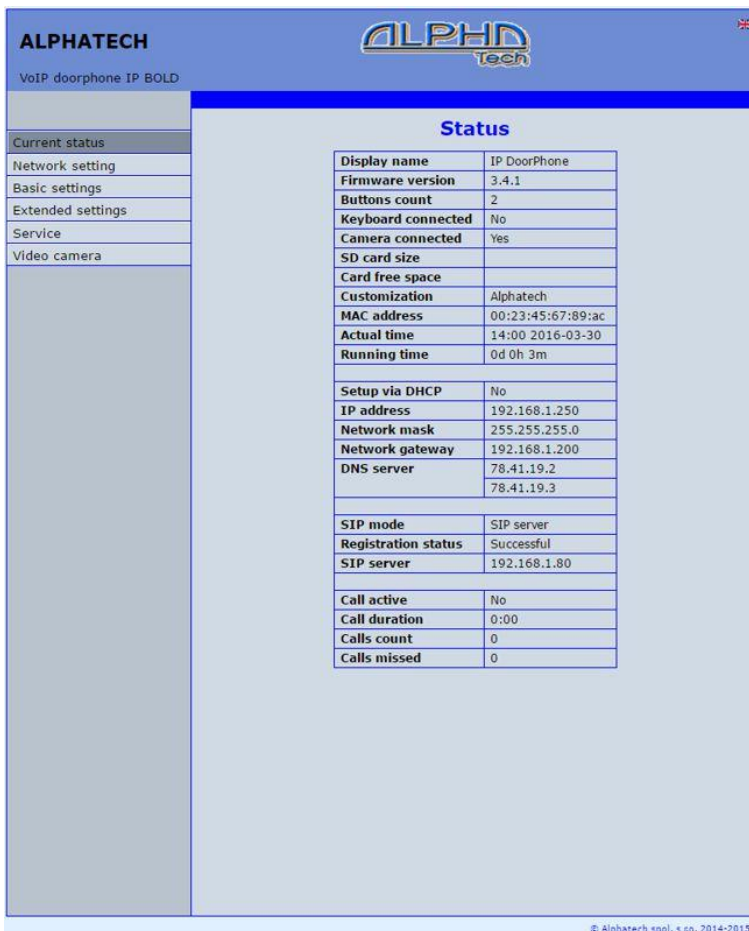

ALPHATECH
VoIP doorphone IP BOLD

Status

Display name	IP DoorPhone
Firmware version	3.4.1
Buttons count	2
Keyboard connected	No
Camera connected	Yes
SD card size	
Card free space	
Customization	Alphatech
MAC address	00:23:45:67:89:ac
Actual time	14:00 2016-03-30
Running time	0d 0h 3m
Setup via DHCP	No
IP address	192.168.1.250
Network mask	255.255.255.0
Network gateway	192.168.1.200
DNS server	78.41.19.2 78.41.19.3
SIP mode	SIP server
Registration status	Successful
SIP server	192.168.1.80
Call active	No
Call duration	0:00
Calls count	0
Calls missed	0

© Alphatech spol. s ro. 2014-2015

Current status display basic data about IP BOLD door entry status. It displays Firmware version, door entry model, options connection (camera, keypad), SD card, MAC addresses, current time, network setting, door entry mode (P2P or SIP server), registration status and small calls statistic.

3.2.1 Language settings

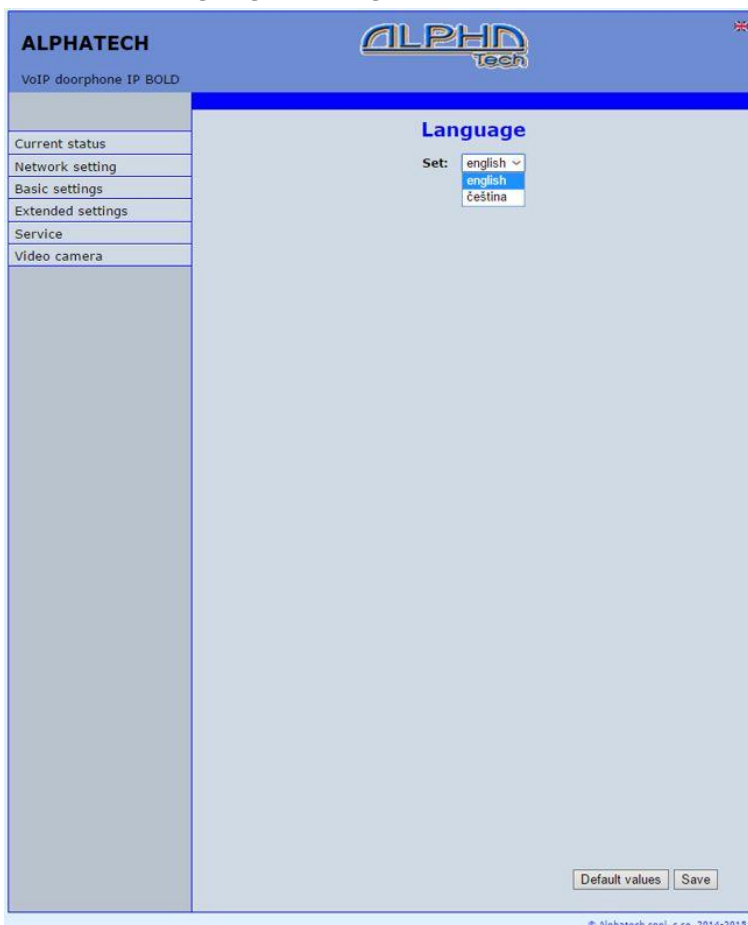

After language selection please don't forget click on „Save“.

On the right top corner is display flag of current used language in whole WEB interface. After click on flag accessible language will be displayed. After language selection please don't forget click on „Save changes“ otherwise language selection wont be performed.

3.3 IP network setting

3.3.1 IP Network setting

Network settings you find in menu „Network setting“. You can select using of fix IP adress or dynamically assigned by using DHCP.

Configuration of fix IP adress:

ALPHATECH VoIP doorphone IP BOLD

ALPHATECH Tech

Current status

Network setting

Network

SIP parameters

Web server

Basic settings

Extended settings

Service

Video camera

Network

Setup via DHCP:

IP address: 192.168.1.250

Network mask: 255.255.255.0

Network gateway: 192.168.1.200

DNS server 1: 78.41.19.2

DNS server 2: 78.41.19.3

NAT policy: No NAT

NAT address:

STUN address: stun.org

Default values Save and restart

© Alphatech spol. s r.o., 2014-2015

After performing of required changes please don't forget click on „Save and restart“.

Setup via DHCP - ON / OFF using DHCP assignment of IP addresses

IP address, Network mask – IP address setting, mask. In case of emergency please contact your network administrator

Network gateway – Router IP adress (Internet connection)

DNS server 1 and 2 – IP addresses of primary and secondary domain server

NAT policy - there is the choice of what kind of translate IP addresses used
NAT address - used for network traffic through the router (modifies transcription of the original or destination IP address)
STUN address - the IP address of the STUN server (see. page. 7)

DHCP configuration:

The screenshot shows the configuration page for the ALPHATECH VoIP doorphone IP BOLD. The page is titled 'Network' and contains the following fields and options:

- Setup via DHCP:**
- IP address:** [Text input field]
- Network mask:** [Text input field]
- Network gateway:** [Text input field]
- DNS server 1:** [Text input field]
- DNS server 2:** [Text input field]
- NAT policy:** [Dropdown menu with 'No NAT' selected]
- NAT address:** [Text input field]
- STUN address:** [Text input field with 'stun.org' entered]

At the bottom right of the configuration area, there are two buttons: 'Default values' and 'Save and restart'.

© Alphatech spol. s r.o. 2014-2015

After performing of required changes please don't forget click on „Save and restart“.

DHCP – by mark of this checkbox as same as saving and restart will be assigned to door entry IP BOLD - IP address by DHCP.

NAT policy - there is the choice of what kind of translate IP addresses used
NAT address - used for network traffic through the router (modifies transcription of the original or destination IP address)

STUN address - the IP address of the STUN server (see. page. 7)

Important: if you use DHCP setting then DHCP assign IP address to door entry automatically and network administrator will assure your current IP address to be able watch video in WEB browser. Therefore this dynamically assigned IP address might be changed due for example power failure we recommend use dooe entry IP **BOLD** with fix IP adress.

3.3.2 SIP setting

The door entry IP BOLD might operate in 2 basic **SIP modes**. It is either **SIP server** – door entry registration is performed to SIP server and then you call to phone numbers assigned by SIP server or **Peer to Peer (P2P)** – door entry call exact IP address and SIP server services can't be used.

Mode SIP server

ALPHATECH VoIP doorphone IP BOLD

SIP parameters

SIP mode: SIP server

Display name: IP DoorPhone

SIP User Agent: IP BOLD

Account: 250

Auth. Id: 250

Password: ***

Send register:

Registration server: 192.168.1.80

Port: 5060

Expiration [sec]: 600

Registrate after restart:

SIP server: 192.168.1.80

Port: 5060

Outbound proxy:

Port: 5060

SIP Transport: TCP & UDP

Provisional code: 180 Ringing

Enable Symmetric RTP:

Registration successful

Default values Save

© Alphatech spol. s r.o. 2014-2015

After performing of required changes please don't forget click on „Save“.

Display name - name by which is device presented in network (for example will display as door entry name in programmes UDV panel, UDVguard)

SIP User Agent – for easy installation is possible use the SIP user agent. The syntax of this string is not defined, but a common practise is „device name + version“.

Account - unit name in SIP protocol (usually line number or name without diacritics)

Auth.ID - name for SIP server registration

Password - password for SIP server registration

Send register – when registration is necessary (mostly yes) then this parameter must be used

Registration server - IP address or server name of registration server (in most systems and installations is enough to insert IP address). Registration is performed on this server. When you don't mark send registration then don't fill *Registration server and IP address of SIP server write to Proxy server*.

Port - SIP port is usually 5060 or 5061

Expiration[sec] – expiration of SIP server registration (period of registration request repeated sending)

Register after restart – when you mark then always during restart will be unregistered

SIP server - IP address or server name. Over this server connection is made. When is not filled then connection makes on *Registration server* (but you must mark *Send registration*)

Port - SIP port is usually 5060 or 5061

Outbound proxy - IP address or proxy name where is determined where will be sends door entry requests. If outbound proxy is setup will be INVITE request sends to outbound proxy address. Outbound proxy is used due NAT. When is not used don't fill up.

Port - SIP port is usually 5060 or 5061

SIP Transport - TCP or UDP, or automatic selection (TCP + UDP)

Provisional code – determine if during ringing will be sends SIP code „180 Ringing“ or „183 Session progress“

Enable symmetric RTP - by mark is ON. It means that door entry will not send by itself audio to RTP called party, but wait for called party to send RTP. After sends data to same address:port from which message arrived. It is trick used for bridging NAT

Registration status display on page as visible on picture.

Peer to Peer mode (P2P)

The screenshot shows the ALPHATECH VoIP doorphone IP BOLD web interface. The top header includes the ALPHATECH logo and the text 'VoIP doorphone IP BOLD'. A left sidebar contains a navigation menu with the following items: 'Current status', 'Network setting' (sub-menu: 'Network', 'SIP parameters', 'Web server'), 'Basic settings', 'Extended settings', 'Service', and 'Video camera'. The 'SIP parameters' sub-menu is selected. The main content area is titled 'SIP parameters' and contains the following configuration fields:

- SIP mode:** Peer-to-peer (dropdown)
- Display name:** IP DoorPhone (text input)
- SIP User Agent:** IP BOLD (text input)
- Account:** 250 (text input)
- Auth. Id:** (text input)
- Password:** (text input)
- Send register:**
- Registration server:** (text input)
- Port:** 5060 (text input)
- Expiration [sec]:** 600 (text input)
- Registrate after restart:**
- SIP server:** (text input)
- Port:** 5060 (text input)
- Outbound proxy:** (text input)
- Port:** 5060 (text input)
- SIP Transport:** TCP & UDP (dropdown)
- Provisional code:** 180 Ringing (dropdown)
- Enable Symmetric RTP:**

At the bottom right of the configuration area, there are two buttons: 'Default values' and 'Save'. A small copyright notice at the bottom of the page reads '© Alphatech spol. s r.o. 2014-2015'.

After performing of changes please don't forget click on „Save“.

Display name – name by which is device presented in network (for example will display as door entry name in programmes UDV panel, UDVguard)

SIP User Agent – for easy inastallation is possible use the SIP user agent. The syntax of this string is not defined, but a common practise is „device name + version“.

Account - unit name in SIP protocol (usually line number), it is recommended to keep filled.

Outbound proxy - IP adress or proxy name where is determine where will be sends door entry requests. If outbound proxy is setup will be INVITE regest sends to outbound proxy adress. Outbound proxy is used due NAT. When is not used dont fill up.

Port - SIP port is usually 5060 or 5061

SIP Transport - TCP or UDP, or automatic selection (TCP + UDP)

Provisional code - determine if during ringing will be sends SIP code „180 Ringing“ or „183 Session progress“

Enable symmetric RTP - by mark is ON. It means that door entry will not sends by itself audio to RTP called party, but wait for called party to send RTP. After sends data to same address:port from which message arrived. It is trick used for bridging NAT.



In active mode - P2P is possible to operate device, which require for their function registration at the SIP server. This option will use new SIP phones, which generally do not support P2P mode, as well as applications for iOS - Apple.

The principle of setting SIP phones and UDV guard, UDV Panel with IP BOLD:

1. Mode of phone is SIP server registration is IP address IP BOLD (registration or SIP server = IP address IP BOLD)
2. Name and password is the line number (we choose a numbering plan so that each number occurred in the network only once, then for each device, fill in name and password to register with this number).

Example:

- IP address of IP BOLD is 192.68.1.250 and the name (page SIP parameters) is **250**
- The IP address of SIP phone 1 is 192.168.1.200, fill in the registration here - SIP server = 192.168.1.250 and name = password = **230**
- The IP address of SIP phone 2 is 192.168.1.201, fill in the registration here - SIP server = 192.168.1.250 and name = password = **231**

Call to SIP Phone 1 is **230**, calls to SIP phone 2 is **231** and calls to IP BOLD is **250**

3.3.3 WEB server

The screenshot shows the ALPHATECH VoIP doorphone IP BOLD web interface. The top header is blue with the ALPHATECH logo and a small flag icon. Below the header, the text "VoIP doorphone IP BOLD" is visible. A left-hand navigation menu contains the following items: "Current status", "Network setting" (with sub-items "Network", "SIP parameters", and "Web server"), "Basic settings", "Extended settings", "Service", and "Video camera". The "Web server" sub-item under "Network setting" is highlighted. The main content area is titled "Web server" and contains the following configuration fields:

- Web interface TCP port: 80
- Service password: [text input field]
- Retype password: [text input field]
- Video on start page:
- Protect video by password:
- Video password: [text input field]

At the bottom right of the configuration area, there are two buttons: "Default values" and "Save and restart". At the very bottom of the page, there is a small copyright notice: "© Alphatech spol. s ro. 2014-2015".

After performing of changes please don't forget click on „Save and restart“.

WEB interface TCP port – possibility of change usually TCP port 80 to other (security reasons)

Service password / Retype password – inserting of new access password (instead default password **1234**) – length max.40 characters (name for access is **admin**)

Video on start page – Video ON/OFF on home page of WEB interface (mainly from security reasons. When video is OFF it is accessible after login with password only).

Protect video by password – further protection is secure access by password to <http://ipaddress/video.jpeg> (camera picture). **CAUTION! this option caused non working video on SNOM phones !**

Video password – inserting of new video access password (instead default password **1234**) – length max.40 characters (name for video access is **video**)

Enable telnet – available only for special customization.

possibility ON / OFF access from telnet (name: root, pass: 8765). Use telnet is not recommended, in practice, this possibility has caused a lot of problems. Damage Doorphone IP BOLD unprofessional intervention via Telnet warranty will be void Doorphone IP BOLD.

3.4 Basic setting

In this part are setup user and most often changed parametres.

3.4.1 Phone book

ALPHATECH VoIP doorphone IP BOLD

Number: 2

Phonebook

Title: Mr. Brown
Email: brown@email.eu
Enabled:

1. call number: 180
Timetable: None
Calling: Group start

2. call number: 229
Timetable: None
Calling: With previous

3. call number: 210
Timetable: None
Calling: Group end

4. call number: 200
Timetable: None
Calling: Sequential

5. call number:
Timetable: None
Calling: Sequential

External code for relay 1:
External code for relay 2:
External code for relay 3:
External code for relay 4:

Default values Save

© Alphatech spol. s r.o. 2014-2015

After performing of changes please don't forget click on „Save“.

The phone book contents 999 subscribers. For first 99 subscribers agree subscriber number with button number. In this version of door entry – IP BOLD is max = 4 button. Therefore first 4 subscribers are most important.

The door entry IP BOLD is equipped by automatic detection of connected devices. So when is not keypad connected then phone book has 1 – 4 position only according model (number of buttons).

Position number in phone book is selected at top bar by click on appropriate numeral. It is possible also listed by 10 (</>) or go to exact position (all by selection in first – highlighted – row).

The 999 subscribers has a sense when keypad is used (models TK) and eventually using touch display for selective subscriber selection from phone book.

Every position of phone book allows insert up to 5 phone numbers with possibility to join some of them (or all) into group and call group of phone numbers simultaneously.

Title – This text has informative character only. In case of display using will be name shown in list selection.

Email - to this email will be sent Info about missed calls with picture or video in case of model (C) or with records (in case or recorder activation). Necessary is setup Emailu – via follow.

Enabled – Item of phone book (also function of appropriate button) is working hen is permitted only (marked). It has a sense for pensions, hotels etc....)

1. call number – is phone number with highest priority. It is call as first (when is used progressive dial mode). 1. Phone number will be dialled with compliance to selected time plan only.

Time table – when is not selected then 1 number is allways active. Usage of 1 phone number might be limited by time plan.

Calling - allows create groups – via follow.

2. call number – is phone number which is dial as second (when is used progressive dial mode). 2nd phone number will be dialled with compliance to selected time plan and when is filled only.

Time table – when is not selected then 2 number is allways active. Usage of 2nd phone number might be limited by time plan

Calling - allows create groups – via follow.

3. call number – is phone number which is dial as thirth (when is used progressive dial mode). 3th phone number will be dialled with compliance to selected time plan and when is filled only.

Time table – when is not selected then 3th number is allways active. Usage of 3th phone number might be limited by time plan

Calling - allows create groups – via follow.

4. call number – is phone number which is dial as fourth (when is used progressive dial mode). 4th phone number will be dialled with compliance to selected time plan and when is filled only.

Time table – when is not selected then 4th number is allways active. Usage of 4th phone number might be limited by time plan

Calling - allows create groups – via follow.

5. call number- is phone number which is dial as fifth (when is used progressive dial mode). 5th phone number will be dialled with compliance to selected time plan and when is filled only.

Time table – when is not selected then 5th number is always active. Usage of 5th phone number might be limited by time plan

Calling - allows create groups – via follow.

External code for relay 1,2,3,4 – here insert private codes for code lock. The code lock might be completed from door entry buttons (mean according buttons 1 – 4 in TC model), or in TK models you can use keypad. Each subscriber has one code for every relay.

Calling – description

The group means that 2 or more phone numbers creates group and those numbers are dialled simultaneously (all are ringing together). Who from dialled subscribers pick up first can talk and ringing to other subscribers in group will be ended.

Individually – this phone number is dialled individually. This not in group with any other number.

Group start – first phone number in group call

In group with previous – phone number in group. This not first and also not last.



Group end – phone number is last from the group

By this setting you can create for every subscriber up to 2 groups or groups with 5 numbers and make groups combination with individual phone numbers.

EXAMPLE: first phone number rings to operator – „Individually“
Second phone number is „Group start“
Third and fourth phone number is „in group with previous“
Fifth phone number is „Group end“

– Those four phone numbers ringing in office together where are picked up by other subscribers when operator is busy. In offices phones start ringing after adjustable time.

3.4.2 Relays

ALPHATECH  

VoIP doorphone IP BOLD

Number: 2 3 4

Relay

Enabled:

Timetable: None

Relay mode: Monostable

Delay time [sec]: 0

Run time [sec]: 5

Source:

Synchronize delay [sec]: 0

Active on call: Ignore

Blocking by:

Acoustic tone: None

Active by HTTP:

Security output code:

Direct ON button:

RC command at relay ON:

RC command at relay OFF:

Code	Source		Timetable
1. 55	DTMF	On	None
2. 11221	Button	On	None
3.	Button	Off	None
4.	Button	Off	None
5.	Button	Off	None
6.	Button	Off	None
7.	Button	Off	None
8.	Button	Off	None
9.	Button	Off	None
10.	Button	Off	None

© Alphatech spol. s r.o. 2014-2015

After performing of changes please don't forget click on „Save“.

In relays setting are accessible 4 relays. The relays 1 and 2 is output of relays contacts directly in IP BOLD door entry. Next 2 relays (3 and 4) is possible use for remote relays (IP relays via follow) or as virtual relay usefull for synchronization to allows creation of more difficult functions of relays. **The relay selection is perform by click to relay number in top highlighted row** – similiary as in phone book.

Enabled – relay function might be eliminated, thus eliminating the synchronization signal for the other relays. Meaning is for example when you want temporarily prevent certain door opening. Then instead of all codes cancellation and their repeated programming simply prohibit this relay. After time out you can easily return relay

with all codes to original function. When such status repeats regularly (for example school) you can use time plan.

Time table – defines time period when relay is working and when not. For example is shop operation time, school, etc..

Relay mode -

monostable – by code is closed and after preprogrammed timeout is open. Using for electrical lock switching, sliding gates control, button press signalling etc... (for control codes setting you must insert „ON” (via follow)

bistable – by code is closed and stay closed till moment of open by other code. For this purpose is beside control codes possibility select „ON” for closing and „OFF” for open. (via follow)

Delay time – is time, between closing code evaluation and relay closing. It has no influence for open code which is performed immediately. Closing time is calculated from real relay closing. Using is for example: *progressive door opening, we setup same closing code for both relays, by this delay is monitored walking time from first to second doors.* This feature is adjustable by synchronization as well. By synchronization delay are available individual codes for each doors control.

Run time – relay closing time in monostable mode (time of electrical lock opening)

Source -

Synchronize from time table 1 - 10 - it is selected time plan for relay and 2 options are available:

Monostable, then always when setup time period in time plan is suitable and time plan is active is perform closing for preprogrammed closing time.

Bistable, then always when setup time period in time plan is suitable and time plan is active the relay is closed and out of those conditions is open.

Synchronize with relay 1 – 4 – relay closing starts closing of the same or other relay. Example for usage is sliding gate control, where by partly opening you can create passage – door substitution. For this mode relay must close for 1 sec in 2 times in sequence. Where period between closing is created passage. (for example 6sec). *The setting make that for relay 1 select monostable mode with time closing 1 sec, synchronization with relay 1 and synchronization delay 7 sec.* In case you need setup situation that for one code (55) relay 1 close 2 pulses in sequence – passage creation and by second code (56) gate will be closed then use not connected relay 4 for synchronization. *Setting of relay 1 is monostable, closing time 1 sec, synchronization with relay 4 and synchronization delay 7 sec. Codes for relay 1 closing are 55 and 56. The relay 4 we setup as monostable, closing time 1 sec, closing code 55.*

By synchronization you can create different closing combination.

Synchronize delay – time between synchronization start and its evaluation.

Usage for example in more relays closing combination for one code

Active on call – options are

none (calling has no influence for relay status)

incoming call – relay closed during incoming call. The monostable for preprogrammed time. The bistable permanently for all call duration.

outgoing call – relay closed during outgoing call. The monostable for preprogrammed time. The bistable permanently for all call duration.

Both call – relay closed during every call. The monostable for preprogrammed time. The bistable permanently for all call duration.

Blocking by: the selection for blocking is the door sensor inputs (1 + 2). As a result of the blocking function, the corresponding inputs must be activated in the door sensor settings (page. 56). The function of the switch is blocked by the state of the input of the selected door sensor. They are used for security doors - if they are not closed, they can not be opened, or a two-door function can be modeled in one input where the second door can only be opened after the first door is closed - security input eg to the ATM. [Input blocks the switch by disconnecting - eg a magnetic switch as for Electronic Security Systems].

Another use is, for example, the possibility of blocking the opening of the lock by the state of the security system - the security is active = the door can not be opened, it is deactivated = the door can be opened.

Acoustic tone – In case of need you can simulate relay closing by sound signal. This feature is usefull mainly in monostable mode in case of PoE feeding of low consumption electrical lock by DC power supply. This sound simulates typical buzzing of electrical lock. Further option is record voice message to SD card for blind people with information about electrical lock opening.

This option has yet another hidden meaning, the LED on the front panel when you turn the acoustic signal indicates the switch is activated lights red + green.

Activate by protocol HTTP – relay status is possible change by sending HTTP request (GET request) to IP adress of door entry. To get working this feature you must permit by parametr relay control by HTTP. Request for door entry must be in following format (you can test by web browser):

command relay switch:

IPaddress / relay_control?r=on where r = number of relays 1-4

E.g. http://192.168.1.250/relay_control?1=on - switches on relay 1 (doorphone to the default IP address)

command to releasing relay:

IPaddress / relay_control?r=off where r = number of relays 1-4

E.g. http://192.168.1.250/relay_control?1=off - switches off relay 1 (doorphone to the default IP address). Releasing the relay is important in the bistable switch mode.

Security output code – relay output is close/open in default. This static status is dangerous in case of unauthorised enter for example by door entry damaged and short circuit wires of power supply and electrical lock. Defence is using module COSW which you connect to electrical lock wires – closest to electrical lock. For relay closing is sends in such connection pulses set and when setup code at COSW match with code of this parametr relay is closed.

Caution – ***do not fill code when electrical lock without COSW is connected. It can damage relay in door entry IP BOLD!***

Direct ON button – when you fill up button number then this number will work as **departure button** only. Eventually might be used relay output for control of mechanical bell. During button press is relay activated in monostable mode for closing time. If in the phonebook filled for this button telephone number then be combined with relay closing with calling telephone number.

RC command at relay ON – Enable setup command sends to external device (for example WEB relay) during relay closing. Command is sending by protokol HTTP (GET request). The command must be in format http://ip_address/command. Specific command, refer to the manufacturer's documentation WEB relay.

RC command at relay OFF- Enable setup command sends to external device (for example WEB relay) during relay opening. Command is sending by protocol HTTP (GET request). The command must be in format http://ip_address/command. Specific command, refer to the manufacturer's documentation WEB relay.

Codes for relay control – here is 10 basic central codes for relay. Moreover every subscriber in phone book has his own private code for relay control (code keylock from buttons). Those 10 codes might be assigned as codes from buttons (code keylock) or by phone (DTMF). Further is possible assign feature relay closing/opening (ON/OFF). The Code validity is discriminated by time according selected time plan.

Examples:

1. Closing switch 1 from the phone (DTMF) – on the picture is filled with code 55 without any time limit, closing the switch is activated by dialing 55 from phone
2. Closing switch 1 from buttons – on the picture is filled with code 11221 with time limitation (open time), closing the switch is activated by pressing a sequence of buttons 11221 on IP BOLD

Practical examples of switch settings:

1. Locking the door lock:
 Phone code: 55
 Button code: 121
 Schedule - time table 1 = work:
 Locking time: 5sec (run time)

Timetable name:

Active	Interval 1	Interval 2	Interval 3
Sun: Yes	-	-	-
Mon: Yes	8:00 - 15:00	-	-
Tue: Yes	8:00 - 15:00	-	-
Wed: Yes	8:00 - 15:00	-	-
Thu: Yes	8:00 - 18:00	-	-
Fri: Yes	8:00 - 13:00	-	-
Sat: Yes	-	-	-

Code for activation:
 Code for deactivation:

Active: Yes
 Switch

a) Codes are active all the time

Enabled:

Timetable:

Relay mode:

Delay time [sec]:

Run time [sec]:

Source:

Synchronize delay [sec]:

Active on call:

Blocking by:

Acoustic tone:

Active by HTTP:

Security output code:

Direct ON button:

RC command at relay ON:

RC command at relay OFF:

Code	Source	On	Timetable
1. 55	DTMF	On	None
2. 121	Button	On	None
3.	Button	Off	None

b) The code from the buttons is limited by the "work"

Code	Source	On	Timetable
1. 55	DTMF	On	None
2. 121	Button	On	2 work
3.	Button	Off	None

c) The function of the entire switch is limited by the "work"

Enabled:

Timetable:

Relay mode:

Delay time [sec]:

Note: The time schedule restrictions can be changed operatively with codes 11 and 10 (see schedule settings- time table). To shorten the time interval - to leave the company prematurely. E.g. on Monday you want to leave at 14am but the interval is set to 8: 00-15: 00. You will use code 10 at 14:00. It is also possible to extend working hours on Friday by dialing code 11 after 13:00. But

then you must not forget to dial code 10 when you actually leave. These codes are of course selected from your phone, in conjunction with the door Communicator

2. Switch 1 switches 2 pulses per command:

Set the same code as in the previous example.

Relay switching time: 1sec

Time between impulses: 6sec (1sec of relay switching from 7sec synchronization delay)

Note: Switch 1 synchronizes with itself.

Enabled:	<input checked="" type="checkbox"/>
Timetable:	None
Relay mode:	Monostable
Delay time [sec]:	0
Run time [sec]:	1
Source:	Relay 1
Synchronize delay [sec]:	7
Active on call:	Ignore
Blocking by:	

3. Automatic gradually switching on switches 1 and next switch 2 on one command - the door behind

This is actually a combination of two previous cases:

Switch 1 is set according to example 1 and switch 2 is set according to example 2.

Note: Switch 2 is synchronized with switch 1.

The code for switch 1 control automatically activates switch 2 for 7 seconds.

The codes for switch 2 control only switch 2.

4. The switch is permanently switched on during a call in time limited by the "work"

Enabled:	<input checked="" type="checkbox"/>
Timetable:	2 work
Relay mode:	Bistable
Delay time [sec]:	0
Run time [sec]:	5
Source:	
Synchronize delay [sec]:	0
Active on call:	Both
Blocking by:	

Note: In the "Activate on call" setting, you can choose whether the switch is switched on every time you make a call, or only when you receive a call or just when you make an outgoing call.

5. The switch switches according to the time schedule (closed for a certain period of time by the weekly timetable "work = time table 1")

Enabled:	<input checked="" type="checkbox"/>
Timetable:	None
Relay mode:	Bistable
Delay time [sec]:	0
Run time [sec]:	5
Source:	Timetable 1
Synchronize delay [sec]:	0
Active on call:	Ignore
Blocking by:	
Acoustic tone:	None

Note: The relay is closed at set intervals, outside of these intervals relay is open. E.g. on Monday from 8:00 to 15:00 is relay closed.

7. The switch is blocked by the door sensor 2 (door opening condition) only at a time specified in time table "work"

Enabled:	<input checked="" type="checkbox"/>
Timetable:	2 work
Relay mode:	Monostable
Delay time [sec]:	0
Run time [sec]:	2
Source:	
Synchronize delay [sec]:	0
Active on call:	Ignore
Blocking by:	Door sensor 2
Acoustic tone:	None

Note: If switch 1 is set as illustrated, switch 1 can only be switched on at intervals given by the "work" time schedule and only when the door sensor input is connected (door contact closed)



Caution: When changing the switch setting (eg. switching from bistable mode to monostable), it is recommended to restart the doorphone to initialize the switch according to the last setting!

3.4.3 Door sensors

Door sensors are special functions of door entry IP BOLD which is optional. It is HW option which is different according button number of each model – inputs for door sensors. There is created information in the system about close/open the door.

ALPHATECH
VoIP doorphone IP BOLD

ALPHATECH
Tech

Door sensors

Input door sensor 1: Disable

Input door sensor 2: Disable

Door sensor
Exit button - Relay 1
Exit button - Relay 2
Exit button - Relay 3
Exit button - Relay 4

Default values Save

© Alphatech spol. s ro. 2014-2015

After performing of changes please don't forget click on „Save“.

Input door sensor 1 / 2 Door sensor or disable – by permission is activated transmission of Info about open / close the door. This Info is display ether on this page – **Now is** – or on home page with video(under video frame will be display frames with this Info. Further is transmitted to programmes UDVguard and UDV panel and as last is possible use it in SNMP.

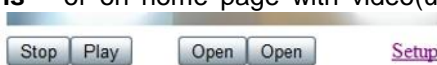

Input door sensor 1 / 2 Exit button – relay 1-4 – because the use of door sensors not found so wide usage, so these can be used as two inputs to the function Exit button. When the input connections (short) so activates the corresponding relay (switch monostabil) .

3.4.4 Setting SNMP

Remote management – SNMP is internet protokol designed for network management. It allows progressive data collection for network management purposes and its following evaluation.

ALPHATECH VoIP doorphone IP BOLD

Setting SNMP

Enable SNMP:

Community: alphatech

Admin address: 192.168.1.22

Variables in MIB tree:

Startup: 0.1.2.3.1.0

Open sensor: 0.1.2.3.2.0

Sensor open timeout: 60

Open sensor for too long: 0.1.2.3.2.1

Entered invalid keycode: 0.1.2.3.3.1

Open relay: 0.1.2.3.1.1

Default values Save

© Alphatech spol. s ro. 2014-2015

After performing of changes please don't forget click on „Save“.

Enable SNMP – by mark you activate remote management (SNMP)

Community – here is necessary select exact user of SNMP

Admin address – setup IP adress or domain name of server where are sent information according defined setting

Variables in MIB tree – is designed for identification of none sense numeral chain OID OID is numeral identifier which definitely identify every value in SNMP communication. OID is created by number sequence separand by dot. Every dot represent exact level of tree structure into

which are OID mapped. The numeral identification in range of each undertree is not Unixe that is why OID is sent allways as whole unit.

3.4.5 Time profiles

ALPHATECH VoIP doorphone IP BOLD

Number: 1 2 3 4 5 6 7 8 9 10

Timetable

Timetable name:

	Active	Interval 1	Interval 2	Interval 3
Sun:	<input type="text" value="No"/>	<input type="text" value=""/>	<input type="text" value=""/>	<input type="text" value=""/>
Mon:	<input type="text" value="Yes"/>	<input type="text" value="8:00 - 16:00"/>	<input type="text" value=""/>	<input type="text" value=""/>
Tue:	<input type="text" value="Yes"/>	<input type="text" value="8:00 - 16:00"/>	<input type="text" value=""/>	<input type="text" value=""/>
Wed:	<input type="text" value="Yes"/>	<input type="text" value="8:00 - 16:00"/>	<input type="text" value=""/>	<input type="text" value=""/>
Thu:	<input type="text" value="Yes"/>	<input type="text" value="8:00 - 18:00"/>	<input type="text" value=""/>	<input type="text" value=""/>
Fri:	<input type="text" value="Yes"/>	<input type="text" value="8:00 - 14:00"/>	<input type="text" value=""/>	<input type="text" value=""/>
Sat:	<input type="text" value="No"/>	<input type="text" value=""/>	<input type="text" value=""/>	<input type="text" value=""/>

Code for activation:
Code for deactivation:

Active:

© Alphatech spol. s ro. 2014-2015

After performing of changes please don't forget click on „Save“.

In time profiles setting is available 10 profiles. **Profile selection is perform by click in top highlighted row** – similiary as in phone book.

Timetable name – for easy orientation you can named every profile.

Period setting table – profile is active when current time match with setup periods. Every day might have up to 3 active periods. Further is possible deactivate whole day (first item on the row select „Active“ – Yes /No) . In example on the picture it is Saturday or whole day setup on active – in example i tis sunday. To use correctly this feature is necessary to setup correct time in the unit (via Date and time setting)

Code for activation / deactivation– immediate switching status profile by using DTMF. If you switch the time profile, then change it takes to meet the closest in time profile changes (according to the times in the table) or switch to another state using DTMF.

Active – display current profile status

Switch – by click you change profile status

3.4.6 Date and time setting

ALPHATECH VoIP doorphone IP BOLD

Number: 2 3 4 5 6 7 8 9 10

Timetable

Timetable name:

	Active	Interval 1	Interval 2	Interval 3
Sun:	<input type="checkbox"/> No	<input type="text" value=""/> - <input type="text" value=""/>	<input type="text" value=""/> - <input type="text" value=""/>	<input type="text" value=""/> - <input type="text" value=""/>
Mon:	<input checked="" type="checkbox"/> Yes	8:00 - 16:00	<input type="text" value=""/> - <input type="text" value=""/>	<input type="text" value=""/> - <input type="text" value=""/>
Tue:	<input checked="" type="checkbox"/> Yes	8:00 - 16:00	<input type="text" value=""/> - <input type="text" value=""/>	<input type="text" value=""/> - <input type="text" value=""/>
Wed:	<input checked="" type="checkbox"/> Yes	8:00 - 16:00	<input type="text" value=""/> - <input type="text" value=""/>	<input type="text" value=""/> - <input type="text" value=""/>
Thu:	<input checked="" type="checkbox"/> Yes	8:00 - 18:00	<input type="text" value=""/> - <input type="text" value=""/>	<input type="text" value=""/> - <input type="text" value=""/>
Fri:	<input checked="" type="checkbox"/> Yes	8:00 - 14:00	<input type="text" value=""/> - <input type="text" value=""/>	<input type="text" value=""/> - <input type="text" value=""/>
Sat:	<input type="checkbox"/> No	<input type="text" value=""/> - <input type="text" value=""/>	<input type="text" value=""/> - <input type="text" value=""/>	<input type="text" value=""/> - <input type="text" value=""/>

Code for activation:
Code for deactivation:

Active: Yes No

© Alphatech spol. s ro. 2014-2015

After performing of changes please don't forget click on „Save“.

Time zone – selection of installation time zone

Network time server – IP adress or domain name of NTP server. When you dont know then by inserted * will IP BOLD find NTP server automatically according own selection. Condition is setup in network setting start gate and DNS.

Daylight saving time – permission to switch daylight time

Actual time– for control is display present time in IP BOLD

3.4.7 E-mail

When you want inform subscriber about missed calls from door entry you can setup IP BOLD to sent out email after every missed call. You can setup own subject and text of email. When you have door entry with camera you can automatically add to email one or more pictures from camera. (Pictures are taken during ringing)

Door entry sends emails to all subscribers who have in phone book preprogrammed valid email adress. When parametr E-mail in phone book is not filled then emails are sent to preprogrammed default email adress.

ALPHATECH VoIP doorphone IP BOLD

E-mail

Enable:

SMTP Server: smtp.alphatech.cz

SMTP Port: 587

SMTP Account: xxxx

SMTP Password:

Message From: jelinek@alphatech.cz

Default message To: jelinek@alphatech.cz

Send timeout [min]: 30

Attach pictures:

Pictures count: 10

Picture interval [sec]: 5

Message Subject: Example

Message body:

```
Hello,  
$Device$ = door entry  
identification  
$Date$ = current date  
$Time$ = current time  
$DialName$ = name of dialled  
subscriber  
$DialNumber$ = dialled phone
```

[Send test message](#)

Default values Save

© Alphatech spol. s r.o. 2014-2015

After performing of changes please don't forget click on „Save“.

Enable – it activates email sending

SMTP server (adress) - SMTP server adress where emails will be sent

SMTP port – adjust in case of none standard SMTP server setting only. SMTP port is setup usually on value 25, but better is use port **587**.

SMTP, there are three systems:

- Port 25 not allow encrypted - it is marked as obsolete, insufficient safety
- Port 465, not a domain hosting - is labeled as not recommended at
- Port **587**, has no maladies previous two, is currently the only **recommended variant**

SMTP account – when SMTP server requires authorization then must be in this field mentioned name for registration to server. In opposite case leave field empty.

SMTP password – password for registration to SMTP server.

Message from– sender e-mail mentioned in sent email.

Default message to – door entry send emails to adress mentioned in phone book at appropriate subscriber. When you leave this field empty then email is sent to default email which you setup in this field. When receiver is not mentioned in phone book as same as default email field the email is not sent. This e-mail is designed also for function control – **Send control message** – when you want verify correct functionality of emails sending then this control message is sent to this email.

Send timeout – Setup max time for which door entry try to deliver email to inaccessible SMTP server

Attach pictures – enable send attachment with one or more Picture taken during ringing.

Pictures count – setup Pictures number which will be attached to email.

Picture interval – setup time between each pictures

Message subject – setup subject of sending email message

Message body – enable correct contents of sending message. You can insert to text special alternative symbols for user name, date and time for door entry identification. Those alternative symbols will be substitute by actual value before email sending. Via follow table of alternative symbols:

\$Device\$ = door entry identification

\$Date\$ = current date

\$Time\$ = current time

\$DialName\$ = name of dialled subscriber

\$DialNumber\$ = dialled phone number

\$User\$ = name of SMTP subscriber

Send test message – when you want verify correct functionality of email sending then control message will be sent to default email

3.5 Extended setting

This part is designed for system setting which are done once during installation or when are problems with device kompatibility.

3.5.1 DoorPhone

The screenshot shows the ALPHATECH VoIP doorphone IP BOLD web interface. The top header features the ALPHATECH logo and the text "VoIP doorphone IP BOLD". A left sidebar contains a menu with the following items: "Current status", "Network setting", "Basic settings", "Extended settings" (which is expanded to show "DoorPhone", "Audio", "Audio codecs", "Video", "Video codecs", and "Streaming"), "Service", and "Video camera". The main content area is titled "DoorPhone" and contains the following settings:

- Ringing timeout [sec]: 30
- Maximum call duration [sec]: 120
- Prolongation key: * - Asterisk -
- Reject all incoming calls:
- Ringing cycles count: 1
- Same key pressed again: Cancel call -
- Another key pressed: Dial -
- Active button by HTTP:
- Dialing timeout [sec]: 2
- DTMF dialing timeout [sec]: 2
- Keyboard mode: Choice number from memory -
- Camera light: During a night call -
- Light intensity [%]: 100
- Labels light: At night -
- Light intensity [%]: 100
- Daylight lower threshold: 250
- Daylight upper threshold: 300

At the bottom right of the settings area, there are two buttons: "Default values" and "Save".

© Alinatech spol. s r.o. 2014-2018

After performing of changes please don't forget click on „Save“.

Ringng timeout – time for which is ringing. When is setup more numbers as same as progressive ringing then after this time ringing is ended on first phone number (IP adress in P2P) and starts ringing on second. It is time until which subscriber must pick up. When is not next number to call then email is sent either to email adress mentioned in phone book or to default email (E-mail setting). Setting range is 5 to 300sec (6min.) caution: it might happen that ringing time will not be limited but it is limited by time parametres of SIP protocol and it is

usually 2-5min (according SIP device setting). You can record message to SD card during this time and simultaneously send email.

Maximum call duration – when call is picked up timer for call duration limit is activated. When you insert empty, then there is no limit. The 10sec before call end you hear tone after which you can dial character for call prolongation and by this prolong the call about same time period.

Prolongation key – options are * or # and usage is described in „Maximal call duration”

Reject all incoming calls - Check to disable any incoming calls. For example, when using a public IP address, the SIP doorphone tries to call several hundred IT robots per hour and blocking the proper doorphone function.

Ringng cycles count– this option enable repeating of call (or progressive call). In phone book is for example filled first and second phone number and not create group. When come condition for first number:

- ringing time is out
- phone number is busy
- subscriber is not reachable / registrated in network

Then second number is dialled. When the same conditions come true and ringing cycles are setup 2 the whole cycle is repeated one more time.

Same key pressed again – when you press again the same button then you setup door entry behaviour. Options are:

- call is hang up
- call is repeated
- nothing happen

Another button is pressed - if you press a different key during a call than you originally pressed, the doorphone behavior is selected:

- dial the telephone number at the currently pressed button
- ignore and nothing happens

Active button by HTTP – if checked, so is possible use http request for remote activation button (like as press the button. This feature is for easy check the installation IP BOLD.

Example:

http:// IPaddress /button_control?btn=1 - remote activate button 1

http:// IPaddress /button_control?btn=27 - remote activate button 27

Dialling timeout – this time concern buttons (keypad) and it is deciding for correct code inserting. When space between button press is longer than this time the code is not correctly evaluated . Situation:

- code keylock provides correct code evaluation
- number dial from keypad –dial end resolution

This time simultaneously prolong dial time at buttons which are initial numbers of codes.

DTMF dialling timeout – this time concerns incoming calls from telephones and it is deciding for correct code inserting . The principle is the same as previous parametr but it concerns codes from telephone.

Keyboard mode – models TK only – **memory number dial** means that you press 1-3 digit code on keypad which determined position in phone book (1-999). The door entry process the call same way as you pressed button on door entry (1-999). **Direct phone numbers dial** means that you dial numbers by keypad as on ordinary phone.

When you have in numbers dial space longer than **maximal number inserting time** then door entry calls. When you want in mode P2P call to IP adress then „.” in IP adress is substitute by  .

Camera light – wideangle camera has possibility of extra lighting when light conditions are not acceptable. The lighting provils by white LEDs (unfortunately infra LED cant be used but advantage is fully colour picture). The door entry has dark sensor and you have following options of lighting:

- OFF, LEDs will never light
- during conversation, LEDs are allways lighting during call independently on surrounding light conditions
- in the night, LEDs are lighting according surrounding light conditions independently on call
- during night call, Led svítí pouze při hovoru a podle okolního osvětlení

Light intensity – here you setup LEDs light intensity

Labels light – name card might be backlighted by 3 ways:

- OFF, name cards will never be back lighted
- in the night , backlighting depends on surrounding light
- name card is permanently back lighted

Light intensity - here you setup backlight intensity

Daylight lower treshold – settings sensitivity ambient light sensor, the lower limit of the window comparator (range 1-1021)

Daylight upper treshold - setting sensitivity ambient light sensor, the upper limit of window comparator (range 1-1021)

ATTENTION The lower limit must always be less than the upper limit, as the difference between the two values is the hysteresis (recommended to maintain approximately 50)

3.5.2 Audio setting

ALPHATECH VoIP doorphone IP BOLD

ALPHATECH Tech

Current status

Network setting

Basic settings

Extended settings

- DoorPhone
- Audio
- Audio codecs
- Video
- Video codecs
- Streaming

Service

Video camera

Audio

Speaker volume: 0 dB

Microphone gain: 0 dB

Echo limiter threshold: 25

Echo limiter attenuation: -36 dB

Echo limiter samples: 2000

Acoustic tone on button pressed: None

Acoustic tone on call start: Default

Acoustic tone on remote ringing: Default

Acoustic tone before call end: Default

Acoustic tone on call end: Default

Acoustic tone on error: Default

Acoustic tone on remote busy: Default

Acoustic tone on unknown number: Default

Acoustic tone on valid code entry: Default

Acoustic tones volume: 0 dB

Relay running tone volume: 0 dB

Default values Save

© Alphatech spol. s ro. 2014-2015

After performing of changes please don't forget click on „Save“.

Speaker volume + Microphone gain – amplification setting

ECHO limiter – it is designed for Echo cancellation which is created by distortion of loud signal. During standard door entry call is working automatic adaptive echo canceller which cancel the echo after cca 3 seconds of talk and call is full duplex. The setting is : High intensity signals coming from phone to speaker of door entry are distorted and automatic echo canceller cant process them. This level of **threshold** you setup (in %). How much should be reduced signal returning through microphone input is adjusted by **attenuation**. Delay of returning signal is adjustable by **samples** amount.

Tone – here you select acoustical signalling of different door entry status.

Options are: - None, this status will not be signalling

- default, simple signalling in default setting
- user, this is recorded signalling by user (SD card) -via. Service

Volume – loudness signalling adjustment

3.5.3 Audio codecs

ALPHATECH VoIP doorphone IP BOLD

Audio codecs

Priority 1: G711μ

Priority 2: G711a

Priority 3: -----

Priority 4: -----

Priority 5: -----

Jitter compensation [msec]: 100

Default values Save

© Alphatech spol. s ro. 2014-2015

After performing of changes please don't forget click on „Save“.

Priority – setting of codecs priority for usage. Some audio codecs requires payable license (for example G729) – codec permission you perform in Servis – license management.

Jitter compensation - jitter means fluctuation of packet delay during network running

3.5.4 Video setting

ALPHATECH VoIP doorphone IP BOLD

ALPHATECH Tech

Current status

Network setting

Basic settings

Extended settings

- DoorPhone
- Audio
- Audio codecs
- Video
- Video codecs
- Streaming

Service

Video camera

Video

Image size: 320 × 240

Quality: Optimal

Brightness: []

Contrast: []

Colour: []

Hue: []

Auto white balance: []

Gamma: []

Power line frequency: Disabled

White balance: []

Sharpness: []

Auto exposure: Software Mode

Exposure: []

Default values Save

© Alphatech spol. s ro. 2014-2015

After performing of changes please don't forget click on „Save“.

Image size— image size selection. Stream H.263 knows just CIF resolution (352x288) so bigger image is cut and smaller image is framed

Images per second – this setting concern mainly image transmission to WEB browser. For H.263(4) is flow control flexibly according processor and network workload and it is in range 5-15 pictures/sec. Maximal flow is possible rejected by choice Low – Optimal – Full.

Further setting is standard image parametres petting and reset is immediatelly visible in Windows screen.

Auto exposure - a choice between three balancing exposure image.

1. Manual mode – you set the exposure manually using the slider Exposure at the bottom

2. Aperture priority mode – automatic exposure is adjusted by the camera module
3. Software mode – exposure calculates and sets the software in IP BOLD



Before adjusting image parameters, it is recommended to use the first Default values..

3.5.5 Video watching (PopUp programm)

The door entry video records by USB WEB camera. The camera image sends either like JPEG pictures set to WEB browser (first page on door entry IP adress) or door entry sends stream video in coding H.263 and H.264. This streaming video you can watch for example on IP phone with LCD display.

Further very popular video watching is using PopUp programm UDVpanel for Windows. This programm including user guide you can download for free on <http://www.alphatech.cz/program-udv-guard.html>. Except showing video has programm following features:

- During call is automatically activated from Windows bar to front and show image from door entry IP BOLD. When call is ended it is minimalize again.
- Enable activate both door entry relays by click – door opening
- Enable acoustical connection with door entry IP BOLD – when door entry calls to PC adress with installed and running programm then you can receive call through sound card in PC. By click to DoorPhone button in programm you can call to door entry IP BOLD – **CAUTION** PC sound card ECHO canceller setting !!
- Programm might be installed to max.100 computers in network. When is active door entry IP BOLD connection then all computers have maximalized Windows with video from door entry. In programm you setup door entry IP adress . Then you can operate more door entries in one network. You assign setup „nameplate“ to appropriate door entry to determine programs to door entries. The „nameplate“ is display in header of UDVpanel programm.
- UDV Panel operates in P2P mode as same as SIP server registration (SIP client) .

For Android operating system you can download programm UDVguard on Google Play for free.

For iOS (Apple) operating system you can download programm UDVguard on AppleStore for free.

3.5.6 Video codecs

The screenshot shows the ALPHATECH VoIP doorphone IP BOLD web interface. The top header features the ALPHATECH logo and the text "VoIP doorphone IP BOLD". The main content area is titled "Video codecs" and contains the following configuration options:

- Video codec priority 1: H263 (dropdown menu)
- Video codec priority 2: H264 (dropdown menu)
- Yealink phone compatibility:
- Snom phone compatibility:

At the bottom right of the configuration area, there are two buttons: "Default values" and "Save".

© Alphatech spol. s ro. 2014-2015

After changes performing please don't forget click on „Save“.

Priority – setting of codecs priority for usage .

Compatibility – Due some of VOIP phones producers specialities you have to use in certain cases extra setting:

Yealink – phonesYealink

SNOM – it is script sending for showing JPEG video. It is unique for SNOM phones

3.5.7 Streaming

The screenshot shows the ALPHATECH VoIP doorphone IP BOLD web interface. The top header is blue with the ALPHATECH logo and a small UK flag. Below the header, the text "VoIP doorphone IP BOLD" is visible. A left-hand navigation menu lists various settings categories: Current status, Network setting, Basic settings, Extended settings (with sub-items: DoorPhone, Audio, Audio codecs, Video, Video codecs, Streaming), Service, and Video camera. The "Streaming" page is active, displaying the following settings:

- Enable streaming:**
- Permitted client:**
- Stream media:** video (selected in a dropdown menu)
- Multicast address:**
- JPEG image quality:** 85 (in a text input field)

At the bottom right of the settings area, there are two buttons: "Default values" and "Save". A small copyright notice "© Alphatech spol. s ro. 2014-2015" is located at the bottom center of the page.

After changes performing please don't forget click on „Save“.

Enable streaming – permitted / prohibited to provide video (H.263 and H264) by door entry IP BOLD (server) protocol RTSP on port 554. To receive such video you need some standard stream video players (IP TV or for example Grandstream, MPlayer, VLC etc...). This video running permanently. It is not depending on calls.

Permitted client – when is not filled up then video might be watch by anybody. When is filled then video is limited just for this IP adress

Stream media – selection of what will be transmitted from RTSP server:

- video
- audio
- video and audio (now not implemented, we prepare)

Multicast address – by inserting IP address you permit sending RTP packets to selected multicasting address.

JPEG image quality – you insert percentage of video coding quality

3.6 Service

This part contents service functions.

3.6.1 Restart

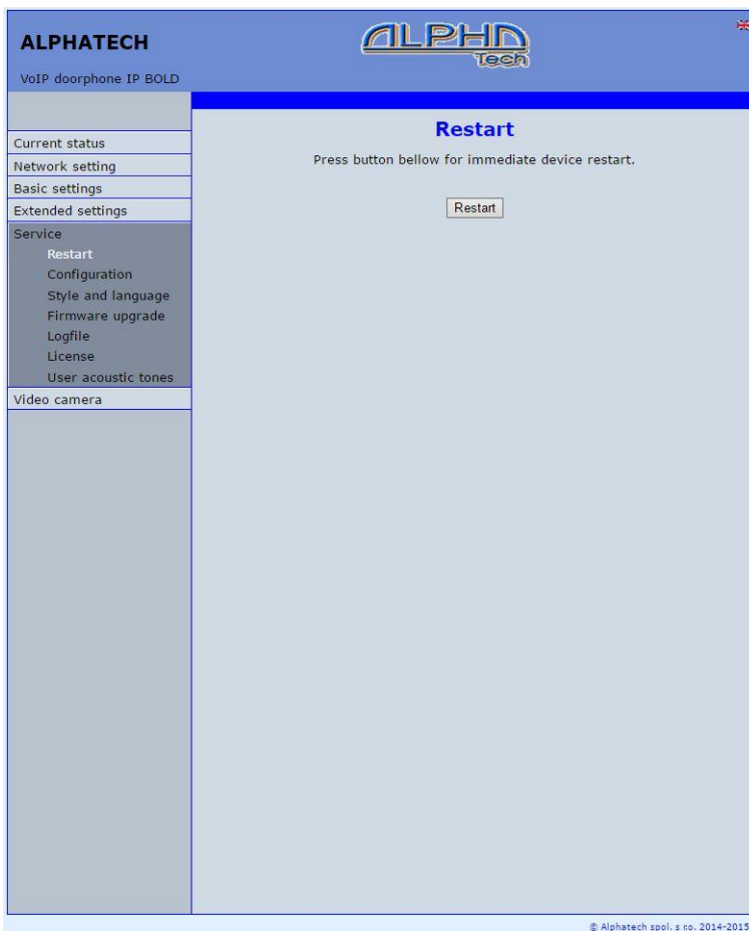

By click on „Restart“ button you make door entry reset.

3.6.2 Configuration

ALPHATECH VoIP doorphone IP BOLD

ALPHATECH Tech

Configuration

Save configuration: [Make](#)

Load configuration:

Load phonebook:

Load network and SIP:

Load others: [Make](#)

Clear phonebook:

Default network and SIP:

Default others: [Make](#)

© Alphatech spol. s no. 2014-2015

The door entry IP BOLD allows saving of current setting to PC or other repository. From this saved file you can later restore this setting in a few levels – for example phone book only. It helps for example during installation of door entry in more entries to the building.

Save configuration – after click to „Make” button will be offered where you can save the file

Load configuration – by click to empty button will be offered file selection. Further is necessary select if phone book, network setting, SIP and other parametres have to be loaded. By click to „Make” button is loaded door entry petting from the file.

Default (factory) setting – is selectable in more levels:

Clear phone book – erase complete phone book into default (all 999 possible items)

Default network and SIP – make default setting of network (IP address 192.168.1.250) and erase SIP setting

Default Others – all remains parameters put to factory setting

By click to „Make” will be done required setting/erasing door entry parameters.

3.6.3 Language and style

The screenshot shows the ALPHATECH VoIP doorphone IP BOLD web interface. The top header includes the ALPHATECH logo and the text 'VoIP doorphone IP BOLD'. A left sidebar contains a navigation menu with the following items: Current status, Network setting, Basic settings, Extended settings, Service (Restart, Configuration, Style and language, Firmware upgrade, Logfile, License, User acoustic tones), and Video camera. The main content area is titled 'Style and language' and contains the following configuration options:

- Load style file:** An empty text input field followed by a 'Make' button.
- Load logo file:** An empty text input field followed by a 'Make' button.
- Clean languages:** An unchecked checkbox.
- Load language file:** An empty text input field followed by a 'Make' button.
- Save language file:** An empty text input field followed by a 'Make' button.

At the bottom right of the interface, there is a small copyright notice: © Alphatech spol. s r.o. 2014-2015.

Load style file – by click to empty field select the file and by click to „Make” is style file (symbols and colours setting) loaded. (If you want use the logo, so in this style file must be HTML directive for show the logo) loaded /*.html/.

File with customization use from firmware V3.4.2 on this place for change the style (design) of WEB pages in doorphone /*.custom/.

To create new **language** we recommend following steps. Firstly make export of language file (language version of exported file is simultaneously selected language (flag in right top corner). Rename this file to new language and open in text editor (**PSPad** is recommended because file has rows ended by LF only and no CR+LF as usual). Character set select UTF8 and make translation. **Translation:** There is displayed a bit of the language file. Translates only the red marked part (**texts**), the rest must be left unchanged, otherwise violates file structure.

```
...
#sip parametry
SIP_TIT="SIP parameters"
SIP_MODE="SIP mode"
SIP_MODE_P2P="Peer-to-peer"
SIP_MODE_SRV="SIP server"
...
```

Save finished file (file name is language and no extension) and import to door entry. The flag will be assigned to language file automatically according row for example. **SYS_FLAG="gb"** for Great Britain. Country code examples (flag codes) are mentioned in bellow table:

CZ	Čzech republic	NL	Holand
GB	Great britain	IT	Italy
SK	Slovakia	DE	Germany
ES	Špain	PL	Poland
FR	France	HU	Hungary
GR	Greece	PT	Portugal

Further codes are according directive ISO-3166-1 alpha-2

Code examples of most often used languages:

Cs	czech	nl	dutch
En	english	it	italian
Sk	slovak	de	german
Es	spanish	pl	polish
Fr	french	hu	hungarian
el	greek	pt	portuguese

Further language codes are according directive ISO 639-1

3.6.5 Firmware upgrade

ALPHATECH VoIP doorphone IP BOLD

ALPHATECH Tech

Firmware upgrade

Firmware version: 3.4.1

Choose firmware file:

© Alphatech spol. s ro. 2014-2015

Firmware version – display present firmware version in door entry IP BOLD

Choose firmware file – by click to empty field select file with firmware (for example apt.firmware it is not file *.zip, but already unzip file – on website are firmware files packed to archive *.zip)

In Windows is display proces so firmware upgrade. When from any reason (power failure, network disconnection etc..) firmware upgrade is not finished then you find backup WEB interface for repeating of firmware upgrade.

If you have any problem so is possible by switch of DIP 2 switch to position on and restart on adres 192.168.1.250 you find backup WEB interface for repeating of firmware upgrade. Name is *admin* and password is *1234*. After, do **not forget** move back **DIP switch 2 to position OFF !**.

 After firmware upgrade you must make restart of doorphone IP BOLD.

3.6.6 Logfile

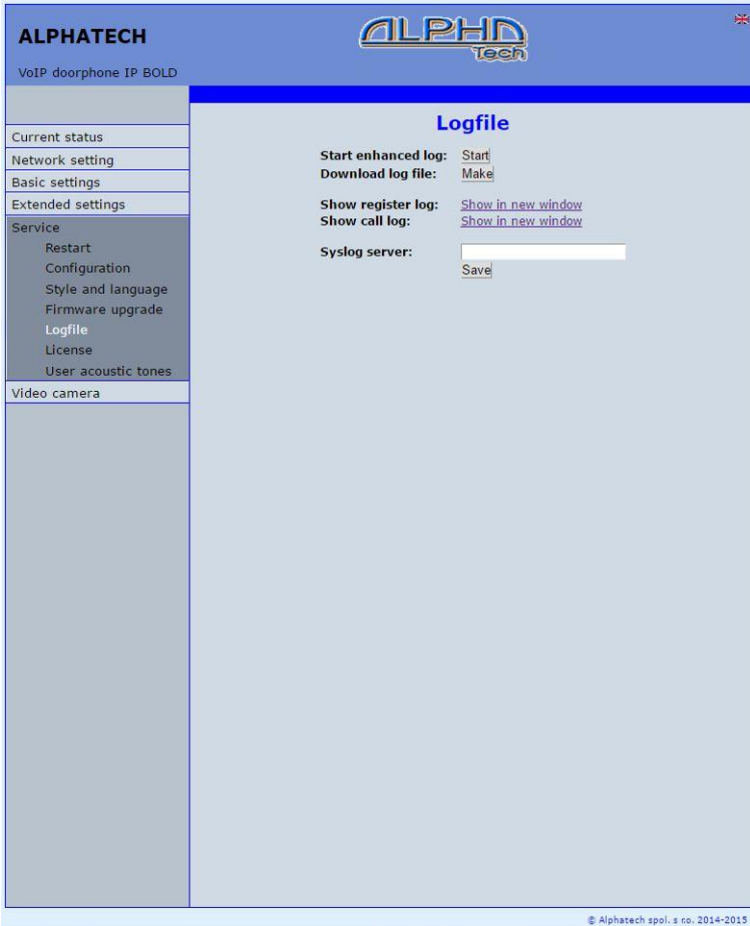

The screenshot shows the ALPHATECH web interface for a VoIP doorphone IP BOLD. The page title is "Logfile". On the left is a navigation menu with categories: "Current status", "Network setting", "Basic settings", "Extended settings", "Service" (with sub-items: Restart, Configuration, Style and language, Firmware upgrade, Logfile, License, User acoustic tones), and "Video camera". The main content area contains the following settings:

- Start enhanced log:** Start
- Download log file:** Make
- Show register log:** [Show in new window](#)
- Show call log:** [Show in new window](#)
- Syslog server:** [Text input field] Save

At the bottom right of the interface, there is a copyright notice: "© Alphatech spol. s no. 2014-2015".

Start enhanced log – it is OFF in default to save processor efficiency. When you switch it ON then are save into internal memory detail information about door entry operation. It is very helpful to solve different problems (compatibility etc..).

Download log file – after activation of enhanced log perform action which doesnt work correctly and immediatelly after performing click on button „Make”. You save like this record of extended log file into file which you send to info@alphatech.cz for further analyses (see procedure. below).

Show call log - in new WEB interface window are online display information about making calls.

Syslog server – IP adress or server name of syslog server where will be sent records about IP BOLD door entry operation (do not forget setup NTP server for setting of internal door entry clocks otherwise records will be saved with incorrect date and time)



The procedure to download Enhanced LOG file. Really send by e-mail LOG downloaded file, do not send copies of screens, videos, etc.

1. Turn enhanced LOG (click Start). Before this step, it is recommended to restart the IP BOLD
2. Perform the action that you are interested in, where you have the problem
3. Immediately download the LOG file uploaded to your PC
4. This file be attached to e-mail a brief description of the problem and send (email contacts on www.alphatech.cz)

3.6.7 License

The screenshot shows the ALPHATECH VoIP doorphone IP BOLD web interface. The top header is blue with the ALPHATECH logo and a UK flag. Below the header, the page title is "License". The left sidebar contains a menu with the following items: Current status, Network setting, Basic settings, Extended settings, Service (with sub-items: Restart, Configuration, Style and language, Firmware upgrade, Logfile, License, User acoustic tones), and Video camera. The main content area displays the "License" page with the following text: "Some features of IP communicators are available only after entering a valid license key." Below this, there is a field for "Codec G729:" with a text input box. To the right of the input box is a "Save" button. Below the button, the text reads: "The license is not valid." At the bottom right of the page, there is a small copyright notice: "© Alphatech spol. s ro. 2014-2015".

This page allows extend door entry features about payable functions via licenses. For example audio codec G729.

After payment you receive license number by email

License validity shows if license is working correctly. The license code is connected to MAC number of door entry.

3.6.8 Sound files

ALPHATECH VoIP doorphone IP BOLD

ALPHATECH Tech

Current status

Network setting

Basic settings

Extended settings

Service

- Restart
- Configuration
- Style and language
- Firmware upgrade
- Logfile
- License
- User acoustic tones

Video camera

User acoustic tones

Acoustic tone on button pressed: Save Clear Play

Acoustic tone on call start: Save Clear Play

Acoustic tone on remote ringing: Save Clear Play

Acoustic tone before call end: Save Clear Play

Acoustic tone on call end: Save Clear Play

Acoustic tone on error: Save Clear Play

Acoustic tone on remote busy: Save Clear Play

Acoustic tone on unknown number: Save Clear Play

Acoustic tone on valid code entry: Save Clear Play

Acoustic tone during relay run: Save Clear Play

© Alphatech spol. s ro. 2014-2015

This page is designed for recording own (user) sounds signalling. By click on „Play“ will be played currently active sound file (selection is performed on page „Audio setting“ eventually sound of relay closing on page „Relays“).

Attention files are recorded on a microSD card!

Audio files: WAV – 8Kbit – mono – 16bit PCM

4 Technical parameters

4.1 Electrical parameters

Parameter	Value	conditions
Interface	Ethernet 10BaseT, 100BaseTx	
VoIP protocol	SIP 2.0 defined RFC3261	
Default IP address	192.168.1.250	
Audio	G.711u, G.711a, G.726-32b, GSM, G722, G729 (optional)	
Band range	300Hz – 3400 Hz	
Echo suppression	automatical	
Output power	Class D, 1W/8ohm, 94dB/1kHz/1m/1%	
Video	série JPEG, MJPG, stream H.263, H.264	
Resolution	Max. 640 x 480	
Camera angle	80deg H x 80deg. V	
Power supply - adapter	12V _{DC} ± 2V , 12V _{AC} ± 1V	
- or PoE	IEEE802.3af Altern. A + B	
Max. consumption	300mA	12V _{ss}
Max. switching voltage by relays	48V	when I < 1A
Max. switching current by relays	2A	when U < 30 V
Temperature range	- 20 to + 80°C	

4.2 Mechanical dimensions

IP BOLD model	dimensions HxWxD [mm]
IP BOLD Tx	205 x 135 x 20
IP BOLD TxC	205 x 135 x 20
IP BOLD TKx	280 x 135 x 20
IP BOLD TKxC	280 x 135 x 20
BOLD Shield S	90 x 140 x 54
BOLD Shield B	208 x 140 x 61
BOLD Shield K	283 x 140 x 61

Water proof and antivandal resistance of all models is IP44

4.3 Video parametres

Video formats: JPG, MJPG, H.263, H.264

Video for WEB:

Internet Explorer, Mozilla, Opera, Firefox... - (set of JPG pictures - Port 80)

it is used repeated http request „IPaddress/video.jpg“

programm PopUp (UDVguard) - (MJPEG stream - Port 80) is used http

request „IPaddress/video.mjpg“ (sometimes is reload necessary to run).This

video is more fluent and has less network strain.

Stream video for IP phones:

H.263 and H264 is established by IP BOLD door entry and IPvideo phone over SIP/SDP protocol on standard SIP port. The video (as same as sound) then runs by RTP protokol on ports agreed over SIP (usually 9078).

rtsp request „rtsp://IPaddress/video.264“

or rtsp request „rtsp://IPaddress/video.263“

Video parametres:

JPG Pictures are created in IP modul and for all transmit protocols are the same .The Size (resolution) of video is selected in "Video setting" on WEB.

Maximal resolution is defined by USB camera type and mostly is 640x480

Stream H.263 knows CIF resolution (352x288). It means bigger JPEG is cut and smaller framed.

Frequency (1-15 picture./sec) JPG Picture is selected in "Video setting" on WEB as Low – Optimal - Full.

Frequency MJPG and Stream H.263 coming from camera. It is used every second and reset is between 7-15 pictures/sec. Higher resolution brings decreasement of Pictures/ sec. (limited by processor efficiency)

Ports:

Port **80** for http (WEB pages even JPG / MJPG video on them)

Port **5060** for SIP

Ports RTP with oposite party communicates over SIP. Usually Port **7078** suggested for audio and Port **9078** for video

Port **554** video(H264 and H263) provided by door entry (server) protocol RTSP

Audio files: WAV – 8Kbit – mono – 16bit PCM

Setup: Default IP adress 192.168.1.250

name: admin / password: 1234

Video: name: video / password: 1234 (if required).

4.3.1 Requests

VIDEO:

JPG - [http:// IPaddress /video.jpg](http://IPaddress/video.jpg)
MJPEG - [http:// IPaddress /video.mjpg](http://IPaddress/video.mjpg)
H.263 - [rtsp:// IPaddress /video.263](rtsp://IPaddress/video.263)
H.264 - [rtsp:// IPaddress /video.264](rtsp://IPaddress/video.264)

RELAYS:

[http:// IPaddress /relay_control?1=on](http://IPaddress/relay_control?1=on)
[http:// IPaddress /relay_control?1=off](http://IPaddress/relay_control?1=off)

[http:// IPaddress /relay_control?2=on](http://IPaddress/relay_control?2=on)
[http:// IPaddress /relay_control?2=off](http://IPaddress/relay_control?2=off)

[http:// IPaddress /relay_control?3=on](http://IPaddress/relay_control?3=on)
[http:// IPaddress /relay_control?3=off](http://IPaddress/relay_control?3=off)

[http:// IPaddress /relay_control?4=on](http://IPaddress/relay_control?4=on)
[http:// IPaddress /relay_control?4=off](http://IPaddress/relay_control?4=off)

BUTTONS:

[http:// IPaddress /button_control?btn=1](http://IPaddress/button_control?btn=1) - remote activate btn 1
[http:// IPaddress /button_control?btn=27](http://IPaddress/button_control?btn=27) - remote activate btn 27

Door sensors:

question:

<http://IPaddress/senstat>

answer:

1st row is sensor 1

2nd row is sensor 2

1=active (connected = close)

0=nonactive (disconnected = open)

X=disable (sensor is not used)

5 General instructions and cautions

1.1 General instructions

Before using this product, please read these operating instructions carefully and follow the instructions and recommendations contained therein.

If the product is used in a manner other than that specified in the manual, the product may be malfunctioning or damaged or destroyed.

Moreover, the manufacturer shall not be liable for any damage or destruction of the product incurred as a result of misplacement, incompetent installation and/or undue operation and use of the product in contradiction herewith.

The manufacturer assumes no responsibility for any malfunction, damage or destruction of the product caused by incompetent replacement of parts or due to the use of reproduction parts or components.

The manufacturer shall not be liable and responsible for any loss or damage incurred as a result of a natural disaster or any other unfavourable natural condition.

The manufacturer shall not be held liable for any damage of the product arising during the shipping thereof.

The manufacturer shall not make any warrant with regard to data loss or damage.

The consumer shall, at its own expense, obtain software protection of the product. The manufacturer shall not be held liable and responsible for any damage incurred as a result of the use of deficient or substandard security software.

The consumer shall, without delay, change the access password for the product after installation. The manufacturer shall not be held liable or responsible for any damage incurred by the consumer in connection with the use of the original password.

The manufacturer also assumes no responsibility for additional costs incurred by the consumer as a result of making calls using a line with an increased tariff.

1.2 Handling of electrical waste and spent batteries



Do not place used electric devices and battery packs into municipal waste containers. An undue disposal thereof might impair the environment! Deliver your expired electric appliances and battery packs removed from them to dedicated dumpsites or containers or give them back to the dealer or manufacturer for environmental-friendly disposal. The dealer or manufacturer shall take the product back free of charge and without requiring another purchase. Make sure that the devices to be disposed of are complete. Do not throw battery packs into fire. Battery packs may not be taken into parts or short-circuited either.

1.3 Notes on Using Open Source Software (GPL)

This product is partly free software distributed under the GNU General Public License version 1, version 2 and version 2.1. Free software release is "as it is" WITHOUT ANY WARRANTY and our LIABILITY. The list of free software and a copy of the license that is used in this product can be downloaded from our website: <http://www.alphatech.cz/english/gpl-code-center.html>

We provide you with a complete, machine-readable copy of the source code of free software at no extra cost. Contact us at info@alphatech.cz

For detailed information on access passwords to the source code for open source software, see also the link above.

Guarantee conditions:

The product was shop-checked. The producer guarantees that this product will keep the features described in these operating instructions in the course of guarantee provided that the user will be handled with it as described in the operating manual. Particularly the warranty does not cover damage from improper intervention via **Telnet**. The guarantee will be extended by period of possible guarantee repair.

When claiming in guarantee period please contact your dealer. The producer only will make the guarantee repairs. Attach the description of claim reason, proof of purchase and your exact address to the product.

The guarantee does not include:

- mechanical, thermal, chemical and other damages caused by user's activities
- defects caused by natural disasters
- defects caused by repair or changes carried out by user or other unauthorized person
- willful damage of product
- incorrect use of product caused by other use than specified in operating manual (e.g. installation, programming, improper use of **Telnet**)
- damages caused during product transport to customer and from supplier

Producer:
Dealer:
Date of sale:



© Alphatech spol. s r.o. 2014-2018 version V1.7